

Instruction Manual



AM 503B & AM 5030 AC/DC Current Probe Amplifiers

070-8766-03

This document applies for firmware version 3.0 and above.

Warning

The servicing instructions are for use by qualified personnel only. To avoid personal injury, do not perform any servicing unless you are qualified to do so. Refer to the Safety Summary prior to performing service.

Copyright © Tektronix, Inc. 1994. All rights reserved. Licensed software products are owned by Tektronix or its suppliers and are protected by United States copyright laws and international treaty provisions.

Use, duplication, or disclosure by the Government is subject to restrictions as set forth in subparagraph (c)(1)(ii) of the Rights in Technical Data and Computer Software clause at DFARS 252.227-7013, or subparagraphs (c)(1) and (2) of the Commercial Computer Software – Restricted Rights clause at FAR 52.227-19, as applicable.

Tektronix products are covered by U.S. and foreign patents, issued and pending. Information in this publication supercedes that in all previously published material. Specifications and price change privileges reserved.

Printed in the U.S.A.

Tektronix, Inc., P.O. Box 1000, Wilsonville, OR 97070-1000

TEKTRONIX and TEK are registered trademarks of Tektronix, Inc.

WARRANTY

Tektronix warrants that this product will be free from defects in materials and workmanship for a period of one (1) year from the date of shipment. If any such product proves defective during this warranty period, Tektronix, at its option, either will repair the defective product without charge for parts and labor, or will provide a replacement in exchange for the defective product.

In order to obtain service under this warranty, Customer must notify Tektronix of the defect before the expiration of the warranty period and make suitable arrangements for the performance of service. Customer shall be responsible for packaging and shipping the defective product to the service center designated by Tektronix, with shipping charges prepaid. Tektronix shall pay for the return of the product to Customer if the shipment is to a location within the country in which the Tektronix service center is located. Customer shall be responsible for paying all shipping charges, duties, taxes, and any other charges for products returned to any other locations.

This warranty shall not apply to any defect, failure or damage caused by improper use or improper or inadequate maintenance and care. Tektronix shall not be obligated to furnish service under this warranty a) to repair damage resulting from attempts by personnel other than Tektronix representatives to install, repair or service the product; b) to repair damage resulting from improper use or connection to incompatible equipment; or c) to service a product that has been modified or integrated with other products when the effect of such modification or integration increases the time or difficulty of servicing the product.

THIS WARRANTY IS GIVEN BY TEKTRONIX WITH RESPECT TO THIS PRODUCT IN LIEU OF ANY OTHER WARRANTIES, EXPRESSED OR IMPLIED. TEKTRONIX AND ITS VENDORS DISCLAIM ANY IMPLIED WARRANTIES OF MERCHANTABILITY OR FITNESS FOR A PARTICULAR PURPOSE. TEKTRONIX' RESPONSIBILITY TO REPAIR OR REPLACE DEFECTIVE PRODUCTS IS THE SOLE AND EXCLUSIVE REMEDY PROVIDED TO THE CUSTOMER FOR BREACH OF THIS WARRANTY. TEKTRONIX AND ITS VENDORS WILL NOT BE LIABLE FOR ANY INDIRECT, SPECIAL, INCIDENTAL, OR CONSEQUENTIAL DAMAGES IRRESPECTIVE OF WHETHER TEKTRONIX OR THE VENDOR HAS ADVANCE NOTICE OF THE POSSIBILITY OF SUCH DAMAGES.

German Postal Information

Certificate of the Manufacturer/Importer

We hereby certify that the **AM 503B and AM 5030** and all factory-installed options comply with the RF Interference Suppression requirements of Postal Regulation Vfg. 243/1991, amended per Vfg. 46/1992.

The German Postal Service was notified that the equipment is being marketed.

The German Postal Service has the right to re-test the series and to verify that it complies.

TEKTRONIX

Bescheinigung des Herstellers/Importeurs

Hiermit wird bescheinigt, daß das **AM 503B and AM 5030** und alle fabrikinstallierten Optionen in Übereinstimmung mit den Bestimmungen der Amtsblatt-Verfügung Vfg. 243/1991 und Zusatzverfügung 46/1992 funkentstört sind.

Der Deutschen Bundespost wurde das Inverkehrbringen dieses Gerätes angezeigt und die Berechtigung zur Überprüfung der Serie auf Einhalten der Bestimmungen eingeräumt.

TEKTRONIX

NOTICE to the user/operator:

The German Postal Service requires that systems assembled by the operator/user of this instrument must also comply with Postal Regulation, Vfg. 243/1991, Par. 2, Sect. 1.

HINWEIS für den Benutzer/Betreiber:

Die vom Betreiber zusammengestellte Anlage, innerhalb derer dieses Gerät eingesetzt wird, muß ebenfalls den Voraussetzungen nach Par. 2, Ziff. 1 der Vfg. 243/1991, genügen.

NOTICE to the user/operator:

The German Postal Service requires that this equipment, when used in a test setup, may only be operated if the requirements of Postal Regulation, Vfg. 243/1991, Par. 2, Sect. 1.8.1 are complied with.

HINWEIS für den Benutzer/Betreiber:

Dieses Gerät darf in Meßaufbauten nur betrieben werden, wenn die Voraussetzungen des Par. 2, Ziff. 1.8.1 der Vfg. 243/1991 eingehalten werden.



EC Declaration of Conformity

We

Tektronix Holland N.V.
Marktweg 73A
8444 AB Heerenveen
The Netherlands

declare under sole responsibility that the

AM 503B Current Probe Amplifier

meet the intent of Directive 89/336/EEC for Electromagnetic Compatibility. Compliance was demonstrated to the following specifications as listed in the official Journal of the European Communities:

EN 50081-1 Emissions:

EN 55011	Radiated, Class A
EN 55011	Conducted, Class A
EN 60555-2	Power Harmonics

EN 50082-1 Immunity:

IEC 801-2	Electrostatic Discharge
IEC 801-3	RF Radiated
IEC 801-4	Fast Transients
IEC 801-5	Surge

Table of Contents

General Safety Summary	ix
Service Safety Summary	xiii
Preface	xv

Getting Started

Customer Support	1-1
AM 503B and AM 5030 System Configuration	1-2
Standard Accessories	1-3
Optional Accessories	1-3
Installing the TM Series Power Module	1-4
Installing the AM 503B or AM 5030 Into the Power Module	1-5
Connecting the Amplifier to an Oscilloscope	1-7
Connecting a Current Probe to the Amplifier	1-8

Operating Basics

Measurements	2-1
Operating the Current Probe Slide	2-1
Degaussing and Autobalancing the Current Probe	2-2
DC Measurements	2-3
AC Measurements	2-4
Control Summary	2-7
AM 503B and AM 5030 Controls	2-8
AM 5030 GPIB Controls	2-12
GPIB Operation	2-13
GPIB Requirements	2-14
Setting the GPIB Parameters	2-14
Other Documents You Will Need	2-15
Functional Command Groups	2-17
Front Panel Commands	2-17
GPIB Status Commands	2-18
Amplifier Status Commands	2-18
Probe Status Commands	2-19
Commands	2-21
ALLeVe? (Query Only)	2-21
AMPS	2-21
BWLIMit	2-22
COUpling	2-22
DCLEVel	2-23
DEGAuss (No Query Form)	2-23
ERRor? (Query Only)	2-24
EVEnt? (Query Only)	2-24
EXit	2-24
FPLock	2-25
HELp? (Query Only)	2-25

ID? (Query Only)	2-26
INIT (No Query Form)	2-26
Overload? (Query Only)	2-26
PATH	2-27
PROBEOPen? (Query Only)	2-27
PROBETRim	2-28
PROBETYPc? (Query Only)	2-29
RQS	2-29
SERIAL? (Query Only)	2-30
SET? (Query Only)	2-30
TEST (No Query Form)	2-31
UNIts? (Query Only)	2-31
Error Messages & Codes	2-33

Reference

Reference Notes	3-1
Degaussing a Probe with an Unpowered Conductor in the Jaws	3-1
Bandwidth Limiting	3-2
Measuring Differential Current	3-2
AC and DC Coupling	3-3
Maximum Current Limits	3-4
Extending Current Range	3-5
Increasing Sensitivity	3-7
Application Notes	3-9
Automobile Charging Systems	3-9
Inductance Measurements	3-11
Continuity Test of Multiple-Conductor Cable	3-14
Measuring Inductor Turns Count	3-14
Error Codes	3-17
Troubleshooting	3-19

Specifications

Warranted Specifications	4-2
Nominal and Typical Characteristics	4-2
Environmental Characteristics	4-4

Performance Verification

Performance Verification Setup	5-1
Test Procedure Conditions	5-1
Equipment Preparation	5-1
Performance Verification with an A6302 or A6302XL	5-3
Required Test Equipment	5-3
Bandwidth	5-4
Rise Time	5-6
DC Accuracy	5-8
Current Loop for DC Accuracy Check	5-8
Performance Verification with an A6303 or A6303XL	5-15
Required Test Equipment	5-15

Bandwidth	5-16
Rise Time	5-18
DC Accuracy	5-20
Performance Verification with an A6304XL	5-27
Required Test Equipment	5-27
Rise Time	5-28
Bandwidth	5-30
DC Accuracy	5-30

Adjustment Procedures

A6302 and A6302XL Adjustment	6-3
Required Test Equipment	6-3
A6302 and A6302XL DC Offset Adjustment	6-3
A6303 and A6303XL Adjustments	6-7
Required Test Equipment	6-7
A6303 and A6303XL DC Offset Adjustment	6-8
A6303 and A6303XL Transient Response and Gain Adjustment	6-10
Optional A6303 Gain Error Adjustment	6-13
A6304XL Adjustments	6-15
Required Test Equipment	6-15
A6304XL DC Offset Adjustment	6-16
DC Gain Adjustment	6-18
A6304XL Transient Response Adjustment	6-20

Maintenance

Customer Maintenance	7-1
Service Strategy	7-1
Preventive Maintenance	7-1
Disassembly	7-3
Static Device Precautions	7-3
Front Panel Knobs	7-4
Side Covers	7-4
Front Panel and Release Lever Assembly	7-4
Front Panel Disassembly	7-7
Using the Rear Interface Output Connector	7-8
Battery Replacement	7-10

Replaceable Mechanical Parts

Replaceable Parts	8-1
Parts Ordering Information	8-1
Using the Replaceable Parts List	8-1
AM 503B & AM 5030 Replaceable Parts	8-3

Glossary and Index

List of Figures

Figure 1-1: Configuring the AM 503B and AM 5030 Current Measurement System	1-2
Figure 1-2: TM Series Power Module Voltage Selector	1-4
Figure 1-3: Changing the TM 502A Operating Voltage	1-5
Figure 1-4: Installing the AM 503B and AM 5030 into the Power Module	1-6
Figure 1-5: Connecting a Current Probe to the Amplifier	1-8
Figure 2-1: A6302 and A6302XL Slide Operation	2-1
Figure 2-2: A6303, A6303XL, and A6304XL Slide Operation	2-2
Figure 2-3: Current Probe Polarity	2-4
Figure 2-4: The AM 503B and AM 5030 Front Panel	2-7
Figure 2-5: Stacked GPIB Connectors	2-13
Figure 2-6: Typical GPIB Network Configurations	2-14
Figure 3-1: Measuring Differential Current and Nulls	3-2
Figure 3-2: Effect of AC or DC Coupling on Low-Frequency Signals	3-3
Figure 3-3: Applying the Amp-Second Product Rule	3-5
Figure 3-4: Increasing the DC Measurement Range	3-6
Figure 3-5: Increasing Probe Sensitivity	3-7
Figure 3-6: Setup for Measuring Charging Current	3-10
Figure 3-7: Charge Current Waveforms	3-10
Figure 3-8: Measuring Inductance with a Low-Impedance Source ..	3-11
Figure 3-9: Linear Current vs. Time Ramp	3-12
Figure 3-10: Measuring Inductance with a High-Impedance Source ..	3-13
Figure 3-11: High-Impedance Source Current Ramp	3-13
Figure 3-12: Measuring the Number of Turns in a Coil	3-14
Figure 3-13: Turns Measurement Using Reference Coil	3-15
Figure 5-1: Bandwidth Test Setup for A6302	5-4
Figure 5-2: Rise Time Test Setup for A6302/A6302XL	5-6
Figure 5-3: DC Accuracy Test Setup for A6302/A6302XL: 1 mA to 50 mA	5-9
Figure 5-4: DC Accuracy Test Setup for A6302/A6302XL: 100 mA to 5 A	5-11
Figure 5-5: Bandwidth Test Setup for an A6303 or A6303XL	5-16
Figure 5-6: Rise Time Test Setup for A6303 or A6303XL	5-18

Figure 5–7: DC Accuracy Test Setup for A6303/A6303XL: 5 mA to 200 mA	5–21
Figure 5–8: DC Accuracy Test Setup for A6303/A6303XL: 500 mA to 50 A	5–23
Figure 5–9: Rise Time Test Setup for the A6304XL	5–28
Figure 5–10: DC Accuracy Test Setup for the A6304XL	5–31
Figure 6–1: A6302 and A6302XL DC Offset Adjustment Location	6–3
Figure 6–2: A6303 and A6303XL Adjustment Locations	6–8
Figure 6–3: A6303 and A6303XL Adjustment Setup	6–11
Figure 6–4: Current Probe Connector Configuration	6–13
Figure 6–5: A6303 Gain Error Correction Curve	6–14
Figure 6–6: A6304XL Adjustment Locations	6–17
Figure 6–7: DC Accuracy Adjustment Setup	6–19
Figure 6–8: A6304XL Adjustment Setup	6–20
Figure 7–1: Removing the AM 503B and AM 5030 Side Covers	7–4
Figure 7–2: Removing the Amplifier Release Lever	7–5
Figure 7–3: Location of Amplifier Interface Cables	7–5
Figure 7–4: Location of Front Panel Screws	7–6
Figure 7–5: Removing the Latch Bar Assembly	7–6
Figure 7–6: Removing the Amplifier Output Connector	7–7
Figure 7–7: Removing the Amplifier Front Panel Board	7–8
Figure 7–8: Using the Rear Interface Output Connector	7–9
Figure 7–9: Prying Battery Terminal to Remove Battery	7–10
Figure 7–10: Removing the Backup Battery	7–10
Figure 7–11: Replacing the Backup Battery	7–11
Figure 8–1: AM 503B & AM 5030 Replaceable Parts	8–3
Figure 8–2: AM 503B & AM 5030 Standard Accessories	8–6

List of Tables

Table 2–1: Front Panel Commands	2–17
Table 2–2: GPIB Status Commands	2–18
Table 2–3: Amplifier Status Commands	2–18
Table 2–4: Probe Status Commands	2–19
Table 2–5: AM 5030 Event Codes	2–33
Table 3–1: Unpowered Circuit Degauss Limits	3–1
Table 3–2: Automobile Charging Systems Test Setup	3–9
Table 3–3: AM 503B and AM 5030 Front-Panel Error Codes	3–18
Table 3–4: Troubleshooting	3–19
Table 4–1: Warranted AM 503B and AM 5030 Specifications	4–2
Table 4–2: Nominal and Typical AM 503B and AM 5030 Characteristics	4–2
Table 4–3: AM 503B and AM 5030 Mechanical Characteristics	4–3
Table 4–4: AM 503B and AM 5030 Environmental Characteristics ..	4–4
Table 5–1: Required Test Equipment	5–3
Table 5–2: Equipment Settings for Bandwidth	5–4
Table 5–3: Equipment Settings for Rise Time	5–7
Table 5–4: Equipment Settings for DC Accuracy	5–9
Table 5–5: DC Accuracy Test for A6302/A6302XL: 1 mA to 50 mA .	5–10
Table 5–6: DC Accuracy Test for A6302/A6302XL: 100 mA to 5 A .	5–12
Table 5–7: DC Accuracy Test Worksheet for A6302/A6302XL	5–13
Table 5–8: Required Test Equipment	5–15
Table 5–9: Equipment Settings for Bandwidth	5–16
Table 5–10: Equipment Settings for Rise Time	5–19
Table 5–11: Equipment Settings for DC Accuracy	5–20
Table 5–12: DC Accuracy Test for A6303/A6303XL: 5 mA to 200 mA	5–22
Table 5–13: DC Accuracy Test for A6303/A6303XL: 500 mA to 50 A	5–23
Table 5–14: DC Accuracy Test Worksheet for A6303/A6303XL	5–25
Table 5–15: Required Test Equipment	5–27
Table 5–16: Equipment Settings for Rise Time	5–29
Table 5–17: Equipment Settings for DC Accuracy	5–31
Table 5–18: DC Accuracy Test for the A6304XL	5–33

Table 5–19: DC Accuracy Test Worksheet for the A6304XL	5–34
Table 6–1: Required Test Equipment	6–3
Table 6–2: Settings for DC Offset Adjustment	6–4
Table 6–3: Error Codes Requiring DC Offset Adjustment	6–5
Table 6–4: Required Test Equipment	6–7
Table 6–5: Settings for DC Offset Adjustment	6–9
Table 6–6: Error Codes Requiring DC Offset Adjustment	6–9
Table 6–7: Settings for Transient Response and Gain Adjustments .	6–11
Table 6–8: Required Test Equipment	6–15
Table 6–9: Settings for DC Offset Adjustment	6–16
Table 6–10: Error Codes Requiring DC Offset Adjustment	6–17
Table 6–11: Equipment Settings for DC Accuracy	6–18
Table 6–12: Equipment Settings for Transient Response	6–20

General Safety Summary

Review the following safety precautions to avoid injury and prevent damage to this product or any products connected to it.

Only qualified personnel should perform service procedures.

While using this product, you may need to access other parts of the system. Read the *General Safety Summary* in other system manuals for warnings and cautions related to operating the system.

Injury Precautions

Ground the Product

This product is grounded through the grounding conductor of the power cord. To avoid electric shock, the grounding conductor must be connected to earth ground. Before making connections to the input or output terminals of the product, ensure that the product is properly grounded.

Do Not Operate Without Covers

To avoid electric shock or fire hazard, do not operate this product with covers or panels removed.

Do Not Operate in Wet/Damp Conditions

To avoid electric shock, do not operate this product in wet or damp conditions.

Do Not Operate in Explosive Atmosphere

To avoid injury or fire hazard, do not operate this product in an explosive atmosphere.

Avoid Exposed Circuitry

To avoid injury, remove jewelry such as rings, watches, and other metallic objects. Do not touch exposed connections and components when power is present.

Keep Probe Surface Clean

To avoid electric shock and erroneous readings, keep probe surface clean.

Product Damage Precautions

- Use Proper Power Source** Do not operate this product from a power source that applies more than the voltage specified.
- Use Proper Voltage Setting** Before applying power, ensure that the line selector is in the proper position for the power source being used.
- Provide Proper Ventilation** To prevent product overheating, provide proper ventilation.
- Do Not Operate With Suspected Failures** If you suspect there is damage to this product, have it inspected by qualified service personnel.

Safety Terms and Symbols

Terms in This Manual These terms may appear in this manual:



WARNING. *Warning statements identify conditions or practices that could result in injury or loss of life.*



CAUTION. *Caution statements identify conditions or practices that could result in damage to this product or other property.*

Terms on the Product These terms may appear on the product:

DANGER indicates an injury hazard immediately accessible as you read the marking.

WARNING indicates an injury hazard not immediately accessible as you read the marking.

CAUTION indicates a hazard to property including the product.

Symbols on the Product The following symbols may appear on the product:



DANGER
High Voltage



Protective Ground
(Earth) Terminal



ATTENTION
Refer to
Manual



Double
Insulated

Certifications and Compliances

CSA Certified Power Cords

CSA Certification includes the products and power cords appropriate for use in the North America power network. All other power cords supplied are approved for the country of use.

Safety Certification of Plug-in or VXI Modules

For modules (plug-in or VXI) that are safety certified by Underwriters Laboratories, UL Listing applies only when the module is installed in a UL Listed product. CSA Certification applies only when the module is installed in a CSA Certified product.



Service Safety Summary

Only qualified personnel should perform service procedures. Read this *Service Safety Summary* and the *General Safety Summary* before performing any service procedures.

Do Not Service Alone

Do not perform internal service or adjustments of this product unless another person capable of rendering first aid and resuscitation is present.

Disconnect Power

To avoid electric shock, disconnect the main power by means of the power cord or, if provided, the power switch.

Use Care When Servicing With Power On

Dangerous voltages or currents may exist in this product. Disconnect power, remove battery (if applicable), and disconnect test leads before removing protective panels, soldering, or replacing components.

To avoid electric shock, do not touch exposed connections.

Preface

This Instruction Manual supports the operation and basic maintenance of the AM 503B and AM 5030 Current Probe Amplifiers.

If you are not familiar with this product, please refer to the *Getting Started* and *Operating Basics* chapters of this manual for basic operating information.

If you are an advanced user, the *Reference* section contains information on advanced applications as well as user diagnostic and troubleshooting information.

The *Performance Verification* and *Adjustment Procedure* sections support the qualification and calibration of the probes when used with either amplifier.

NOTE. *Except for the A6303, once a probe has been calibrated, it can be used with any other AM 503B or AM 5030 without readjustment.*

The *Maintenance* section supports the routine maintenance and repair of mechanical parts associated with the amplifiers.

The *Glossary* and *Index* are provided as quick reference locators for important information.

Related Manuals

You can find the documentation supporting the maintenance and repair of the current probes in the following manuals:

- *A6302 & A6302XL Instructions*
- *A6303 & A6303XL Instructions*
- *A6304XL Instructions*

Manual Conventions

The term “Amplifier” is used to refer to either the AM 503B or AM 5030 when referring to common attributes. If a subject is unique to either amplifier, the amplifier will be referred to directly by model.



Getting Started

Getting Started

The AM 503B and AM 5030 current probe amplifiers let you use one probe to simultaneously measure AC and DC current. The Amplifier converts the sensed current into a proportional voltage signal that you can measure directly with an oscilloscope.

The AM 503B and AM 5030 provide better linearity than other current measurement systems because of a current feedback process used with the probe. DC measurement capability and high bandwidth allow the Amplifier to accurately represent square waves and fast-rise signals.

The AM 503B and AM 5030 provide these features:

- Simultaneous DC and AC current measurements.
- High sensitivity.
- One-button autobalancing and probe degaussing.
- No adjustments needed to match a current probe to an individual amplifier (except for the A6303 current probe).
- Probe trim adjust allows fine tuning of gain for increased accuracy.

The AM 5030 provides an additional feature:

- Programmable control from a GPIB controller.

Customer Support

To help you get the best performance from your Amplifier, Tektronix offers the following customer support services.

Operational Support

If you need assistance operating your amplifier system, please call our Customer Support Center at 1-800-TEK-WIDE (1-800-835-9433), extension 2400. If you are outside the United States or Canada, please contact your nearest Tektronix Service Center.

Service Support

Should your Amplifier system need repair beyond that described in this manual, please contact your nearest Tektronix Service Center.

Sales Support To order optional equipment and accessories, call the Tektronix National Marketing Center at 1-800-426-2200. If you are outside the United States or Canada, please contact your nearest Tektronix Service Center.

AM 503B and AM 5030 System Configuration

A complete AM 503B or AM 5030 current measurement system consists of a current probe amplifier, a compatible current probe, a TM 500 or TM 5000 series power module, and an appropriate oscilloscope. Refer to Figure 1-1.

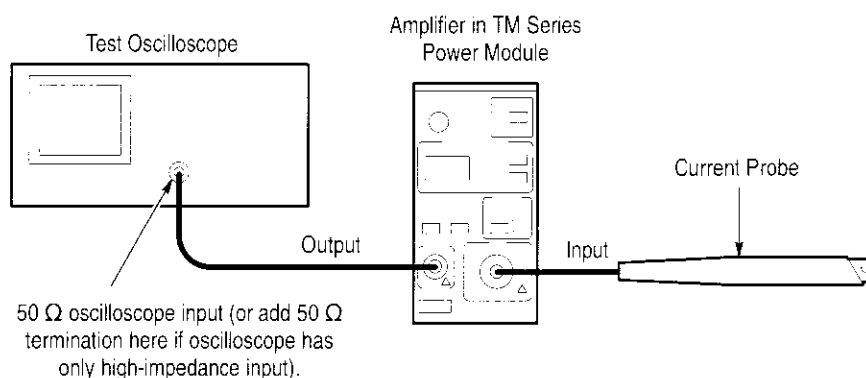

Figure 1-1: Configuring the AM 503B and AM 5030 Current Measurement System

AM 503B & AM 5030 Current Probe Amplifier

The AM 503B is a single-width instrument that plugs into any Tektronix TM 500 or TM 5000 series power module. The AM 5030 is a single-width instrument that plugs into any Tektronix TM 5000 series power module. The Amplifier amplifies the current sensed by the probe and converts the current to a proportional voltage that is displayed on an oscilloscope or other similar measuring device.

Current Probes

The AM 503B and AM 5030 systems may be used with the following Tektronix probes:

- A6302 and A6302XL (20 amps)
- A6303 and A6303XL (100 amps)
- A6304XL (500 amps)

You can also use the CT-4 High-Current Transformer with the A6302 and A6302XL current probes to extend their AC current measurement range to 20,000 peak amps.

TM 500 Series Power Modules

The AM 503B operates in a Tektronix TM 500 or TM 5000 series power module that powers one or more TM 500 series instruments. The Power Module operates on either 110 or 220 VAC, 50 or 60 Hz.

TM 5000 Series Power Module

The AM 5030 operates in a Tektronix TM 5000 series power module that powers one or more TM 5000 series instruments while providing GPIB support. The Power Module operates on either 110 or 220 VAC, 50 or 60 Hz.

Oscilloscope

An oscilloscope displays the output from the current measuring system. A 50 Ω cable is included to connect the Amplifier to the oscilloscope input channel.

If the oscilloscope does not have an input that can be set to 50 Ω impedance, you need a feedthrough 50 Ω termination. This termination is included as a standard accessory with your AM 503B and AM 5030 Current Probe Amplifier.

Standard Accessories

These accessories are shipped with either the AM 503B or AM 5030:

- 50 Ω coaxial cable
- 50 Ω feedthrough termination
- Instruction Manual
- Reference card

If you ordered an AM 503S system, you will have received these items:

- AM 503B
- Current Probe (specific probe type depends on option ordered with the Amplifier)
- TM 502A Power Module
- Toolbox
- AC Power cord

Optional Accessories

You can order the following optional accessories for the AM 503B and AM 5030 Current Probe Amplifiers. Refer to the Replaceable Parts List on page 8–6 for Tektronix part numbers to use in ordering these accessories.

- One-turn 50 Ω current loop. The current loop is used in the performance verification procedure for checking the performance of the AM 503B and AM 5030.
- If you need to measure high-amplitude AC currents, consider using a Tektronix CT-4 High-Current Transformer with the A6302 or A6302XL probes. The CT-4 provides step-down ratios of 20:1 or 1000:1. For more information about the CT-4, consult your Tektronix sales representative.

Installing the TM Series Power Module

If you ordered your current probe amplifier as a part of a system, a power module will have been provided. Follow these instructions for the proper setup and installation of the power module.

The TM Series Power Module can operate from one of four AC line voltages. The operating voltage is determined by the voltage selector, located on the rear panel of the TM Series Power Module, as shown in Figure 1–2.



WARNING. To avoid personal injury or equipment damage, do not connect the power module to the AC line receptacle or turn the power module on until you have verified that the proper operating voltage is selected.

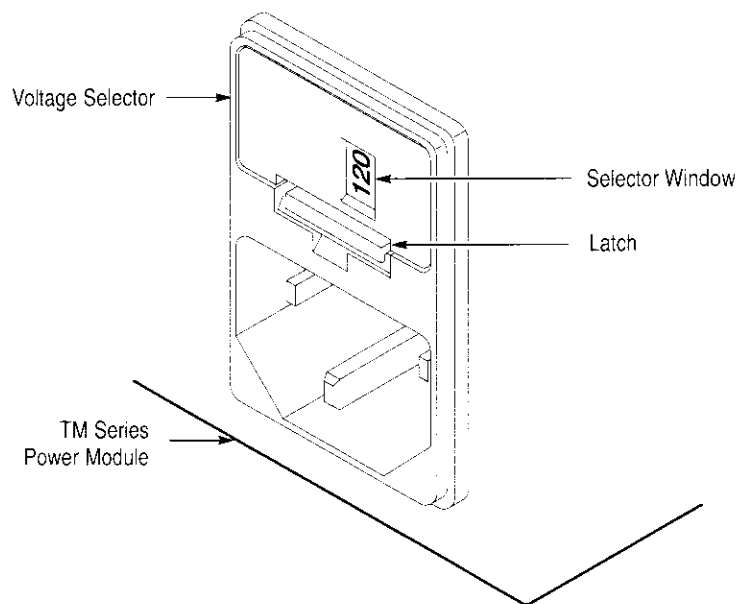

Figure 1–2: TM Series Power Module Voltage Selector

The value displayed in the voltage selector window should match the value of your line voltage. If the two values don't match, perform these steps to select the correct value:

1. Push up on the latch and pull the voltage selector assembly out.
2. Disassemble the voltage selector as shown in Figure 1-3.
3. Rotate the fuse block until the proper voltage appears in the window.
4. Reassemble the voltage selector and push it back into the power module until it snaps into place.
5. Using the correct power cord, connect the power module to the AC line receptacle.

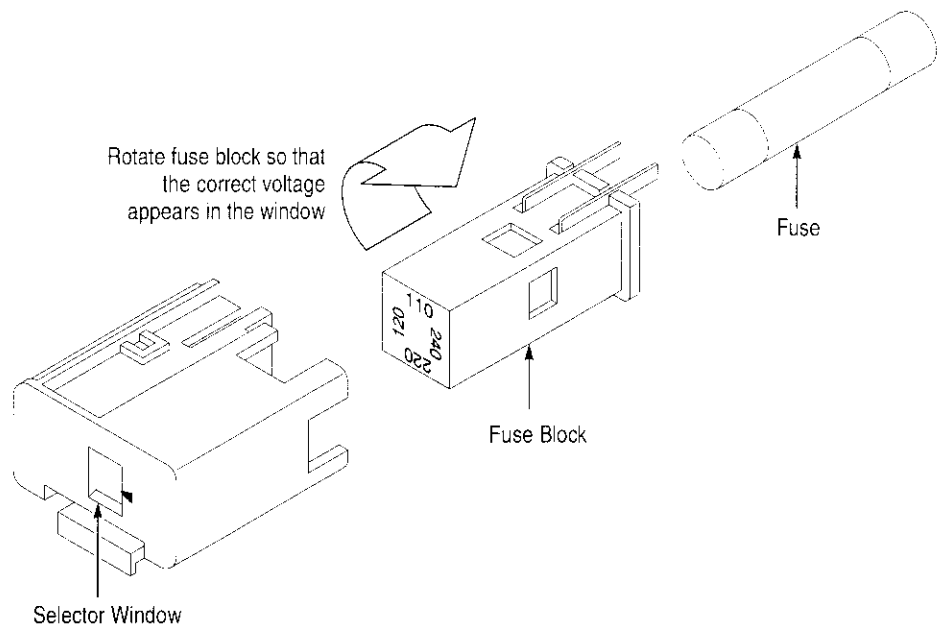

Figure 1-3: Changing the TM 502A Operating Voltage

Installing the AM 503B or AM 5030 Into the Power Module



CAUTION. Make sure the power switch of the power module is turned off before installing the Amplifier. If you install or remove a plug-in instrument while the power module is on, you could damage the power module, the Amplifier, or the current probe.



CAUTION. Do not attempt to install an AM 5030 amplifier into a TM 500 series power module. The backplane connector scheme is different, and damage to the amplifier will result.

To install the Amplifier into the power module, align the grooves of the Amplifier with the rails of the power module and push the Amplifier into the power module until the instrument snaps into place (see Figure 1-4). To remove the Amplifier, grasp the release lever at the lower left corner of the Amplifier front panel and pull the Amplifier out of the power module.

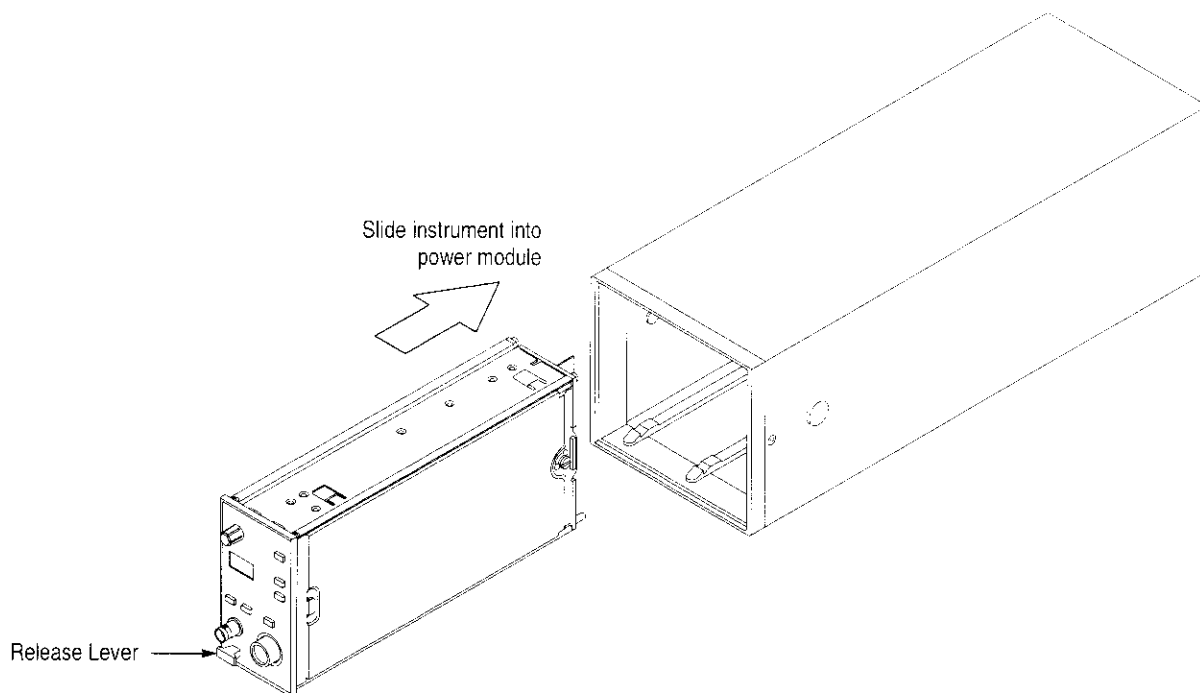

Figure 1-4: Installing the AM 503B and AM 5030 into the Power Module

After you have installed the Amplifier and all other desired plug-in instruments into the power module, you may turn the power module on. A digital readout should appear on the Amplifier front panel and a coupling light should come on. See Figure 2-4 on page 2-7 for the location of the coupling lights.

NOTE. When the AM 5030 is not connected to a GPIB controller, the SRQ light is normally on.

Connecting the Amplifier to an Oscilloscope

You will need an oscilloscope to display the AM 503B and AM 5030 measurement output. The oscilloscope must be capable of displaying a vertical scale factor of 10 mV/div.

Use the supplied 50 Ω BNC cable to connect the Amplifier OUTPUT connector to your oscilloscope (see Figure 1-1 on page 1-2).

The input impedance of the oscilloscope channel must be 50 Ω , otherwise you will encounter slowed pulse response, increased aberrations, or incorrect DC measurement amplitudes. If your oscilloscope provides only 1 M Ω inputs, you need to attach a 50 Ω feed-through termination between the oscilloscope input and the BNC cable. Do not install this termination at the Amplifier end of the BNC cable.

To utilize the full bandwidth capability of the AM 503B and AM 5030 and attached current probe, the oscilloscope bandwidth should be approximately five times that of the current probe. For example, when using an A6302 Current Probe, the oscilloscope bandwidth should be at least 250 MHz. When using an A6303 Current Probe, the oscilloscope bandwidth should be at least 75 MHz.

After you have connected the Amplifier to the oscilloscope, make the following adjustments to the oscilloscope channel you are using. Perform these adjustments only after all equipment has warmed up to a stable temperature; usually 20 minutes are required.

1. Make sure the oscilloscope input impedance is 50 Ω . If your oscilloscope provides only 1 M Ω inputs, you need to attach a 50 Ω feedthrough termination between the oscilloscope input and the BNC cable. Do not install this termination at the AM 503B and AM 5030 end of the BNC cable.
2. Set the vertical gain of the oscilloscope to 10 mV/div.
3. Set the oscilloscope ground reference so the trace appears at the center graticule line or at the desired zero-current reference.
4. Set the input coupling of the oscilloscope to DC.
5. Turn off any oscilloscope bandwidth filters.

Once you have set up the oscilloscope, you do not need to further adjust the oscilloscope vertical controls while you are using the AM 503B and AM 5030. Use the oscilloscope controls to adjust the time base or trigger settings only.

NOTE. To maintain accurate readings while using the AM 503B and AM 5030, the vertical gain of the oscilloscope channel must always remain at 10 mV/Div and the coupling must remain at DC.

Connecting a Current Probe to the Amplifier

To connect a current probe to the Amplifier input connector, align the tab of the probe connector with the slot in the Amplifier **INPUT** connector as shown in Figure 1–5(a). Align the dot on the probe connector with the groove opening of the input connector as shown in Figure 1–5(b). Push the probe connector in while twisting the barrel clockwise to lock the connector.



CAUTION. Handle current probes with care. Do not drop a probe or subject it to impact, or the core may crack. Do not connect or disconnect a current probe while the probe is clamped around a live conductor, or while the AM 503B and AM 5030 is powered on, or the probe may suffer electrical damage.

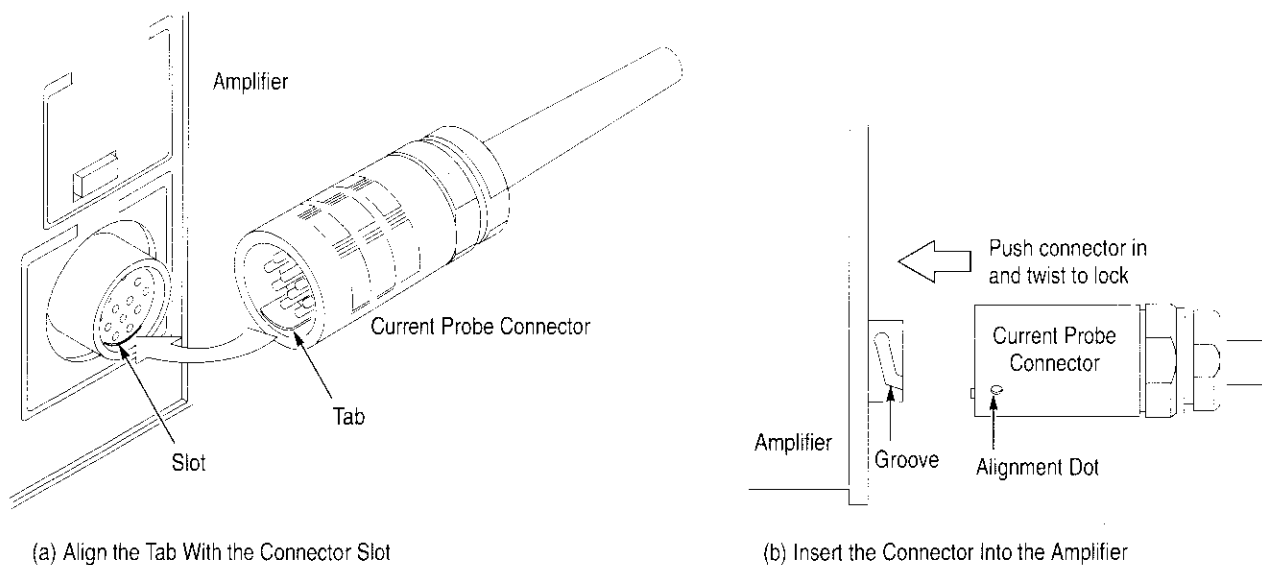

Figure 1–5: Connecting a Current Probe to the Amplifier

Each current probe is calibrated before it is shipped, and should not require further adjustment. If a probe requires adjustment, refer to the *Adjustment Procedure* on page 6–1 or contact your nearest Tektronix Service Center. The adjustment procedure should be performed only by qualified service personnel.



Operating Basics

Measurements

This section provides operating techniques and measurement procedures for using the AM 503B and AM 5030-compatible current probes.

Operating the Current Probe Slide

The current probes each have a slide mechanism that opens and closes the probe jaw. This allows you to clamp the probe around a conductor under test. The slide must be locked closed to accurately measure current or to degauss the probe. If a probe is unlocked, the PROBE OPEN indicator on the Amplifier will light.



WARNING. When the probe slides are open, the exposed ferrite core pieces are not insulated. To avoid injury or equipment damage, remove power from an uninsulated wire before clamping the current probe around it.

Figure 2-1 illustrates the slide operation of the A6302 and A6302XL current probes. To open the probe, pull the slide back until the jaw is open. To lock the probe, push the slide forward until the detent snaps into place.

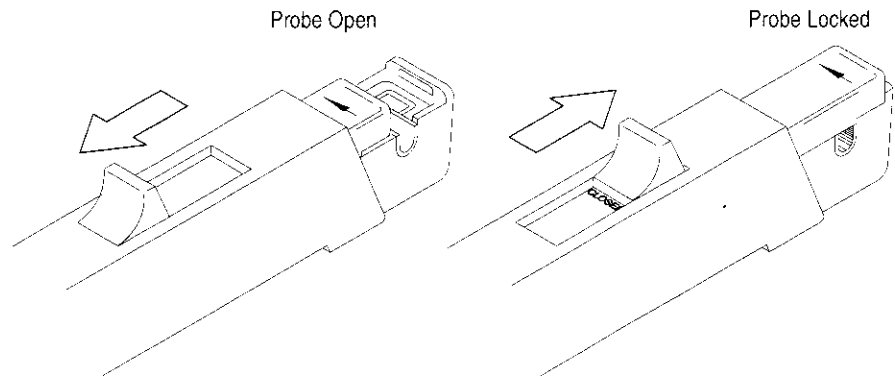

Figure 2-1: A6302 and A6302XL Slide Operation

Figure 2-2 illustrates the slide operation of the A6303, A6303XL, and A6304XL current probes. To open the probe, press the bottom of the lock button and squeeze the handle until the core is open. To lock the probe, release the squeeze handle and press the top of the lock button.

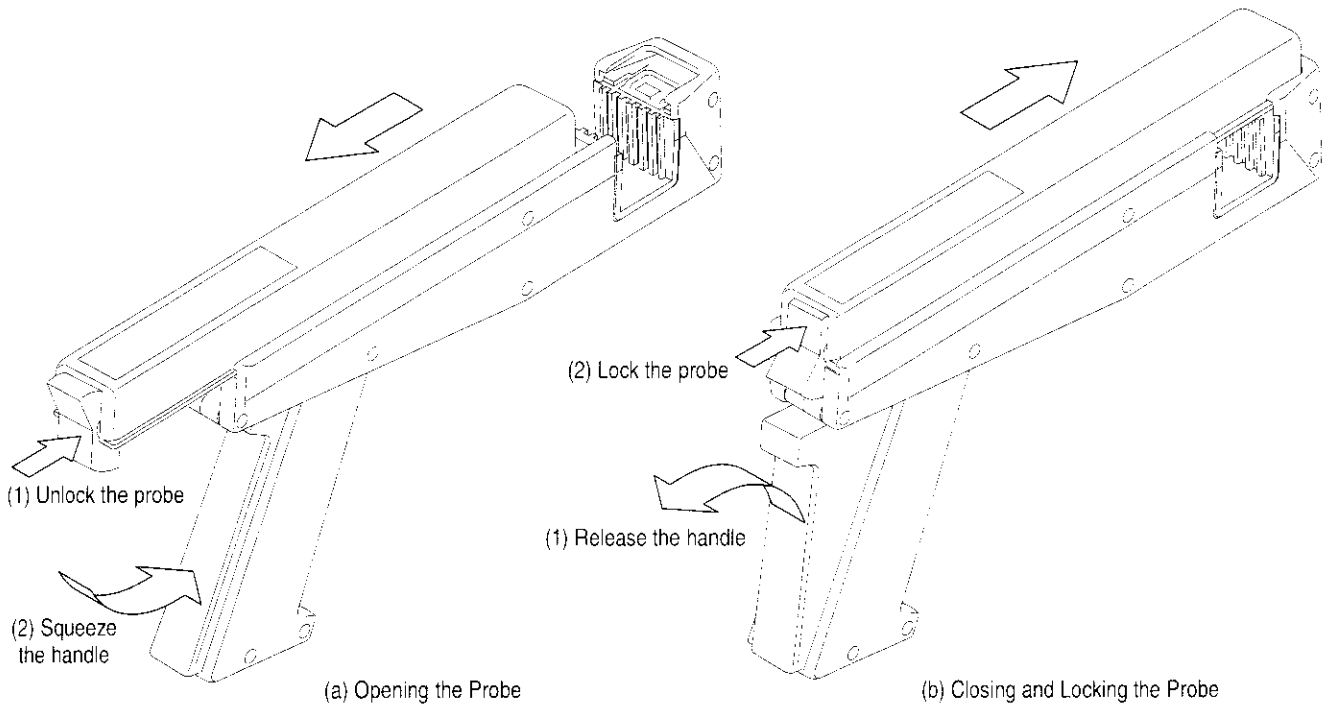

Figure 2–2: A6303, A6303XL, and A6304XL Slide Operation

Degaussing and Autobalancing the Current Probe

Degaussing the probe removes any residual magnetization from the probe core. Such residual magnetization can induce measurement error. Autobalancing removes unwanted DC offsets in the amplifier circuitry.

Failure to degauss the probe is a leading cause of measurement errors. To maintain measurement accuracy, degauss your probe in each of these cases:

- After turning on the Amplifier and allowing a 20-minute warm-up period.
- Before connecting the probe to a conductor or changing conductors under test.
- Whenever an overload condition occurs.
- Whenever the probe is subjected to a strong external magnetic field.
- Periodically during normal use.

To degauss and autobalance a current probe, perform these steps:

1. Verify that the current probe is connected to the Amplifier.
2. Remove the current probe from the conductor under test.
3. Lock the probe slide closed (see Figures 2–1 and 2–2).
4. Press the Amplifier **PROBE DEGAUSS AUTOBALANCE** button.

NOTE. *The degauss procedure will fail if the Amplifier is not properly connected to an oscilloscope having 50 Ω input impedance. If this occurs, an error code of 266 will be displayed on the Amplifier front panel.*

After you have completed the oscilloscope adjustments and the Amplifier degauss/autobalance procedure, your system is ready to measure current.

DC Measurements

To measure DC current, perform these steps:

1. Verify that the vertical gain of the oscilloscope is 10 mV/div, the input coupling is DC, and the input impedance is set to 50 Ω .
2. Adjust the ground reference of the oscilloscope to move the trace to the desired graticule line.

NOTE. *Once the first two steps have been completed, no further adjustments are required on the oscilloscope vertical amplifier during the measurement session. Use the Amplifier controls for everything except time base and trigger adjustment. See Figure 2–4.*

3. Lock the probe closed without a conductor passing through it. Press the Amplifier **COUPLING** button repeatedly until the REF light comes on, and then press the Amplifier **PROBE DEGAUSS AUTOBALANCE** button.
4. After the degauss/autobalance routine completes, adjust the ground reference (if necessary) using the Amplifier **OUTPUT DC LEVEL** control.
5. Open the probe slide, place the probe around the conductor under test, and then lock the slide. For correct measurement polarity, make sure the probe arrow is pointing in the direction of conventional (positive to negative) current flow. Reversing the flow will display the current waveform upside-down on the oscilloscope.

6. Press the Amplifier **COUPLING** button repeatedly until the DC light comes on. Set the Amplifier **CURRENT/DIVISION** to the desired setting using the \uparrow and \downarrow buttons.
7. If necessary, vertically position the resulting waveform using the **OUTPUT DC LEVEL** knob of the Amplifier.
8. Adjust the oscilloscope time base and trigger as needed.

Figure 2–3 shows a current probe connected to a power supply line. Notice that the probe arrow points toward the negative terminal of the power supply to conform to the conventional current flow of positive (+) to negative (–).

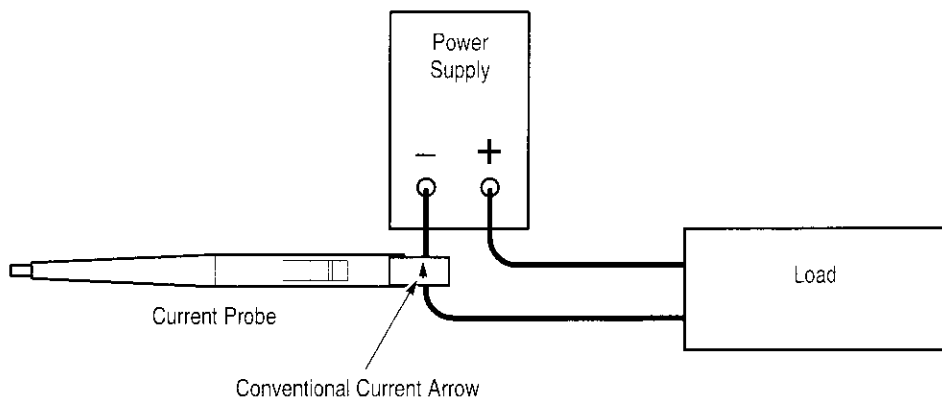

Figure 2–3: Current Probe Polarity

AC Measurements

To measure AC current only, and remove the DC component of the current being measured, follow the instructions below. These are identical to the instructions for DC current measurements except that the Amplifier coupling in step 6 is set to AC.

1. Verify that the vertical gain of the oscilloscope is 10 mV/div, the input coupling is DC, and the input impedance is set to 50 Ω .
2. Adjust the ground reference of the oscilloscope to move the trace to the desired graticule line.

NOTE. Once the first two steps have been completed, no further adjustments are required on the oscilloscope vertical amplifier during the measurement session. Use the Amplifier controls for everything but time base and trigger adjustment.

3. Lock the probe closed without a conductor passing through it. Press the Amplifier **COUPLING** button repeatedly until the REF light comes on, and then press the Amplifier **PROBE DEGAUSS AUTOBALANCE** button.
4. After the degauss/autobalance routine completes, adjust the ground reference (if necessary) using the Amplifier **OUTPUT DC LEVEL** control.
5. Open the probe slide, place the probe around the conductor under test, and then lock the slide. For correct measurement polarity, make sure the probe arrow is pointing in the direction of conventional (positive to negative) current flow. Reversing the flow will invert the displayed current waveform on the oscilloscope.
6. Press the Amplifier **COUPLING** button repeatedly until the AC light comes on. Set the Amplifier **CURRENT/DIVISION** to the desired setting using the \uparrow and \downarrow buttons.

NOTE. *Even when making AC current measurements, leave the oscilloscope coupling on DC. Change only the Amplifier coupling to AC. Using the oscilloscope AC coupling may cause the Amplifier to exceed its output dynamic range.*

7. If necessary, vertically position the resulting waveform using the **OUTPUT DC LEVEL** knob of the Amplifier.
8. Adjust the oscilloscope time base and trigger as needed.

Control Summary

This section describes the function of each AM 503B and AM 5030 front panel control and connector. The overview in Figure 2-4 is followed by a detailed description.

Some seldom-used functions do not appear in Figure 2-4. These functions are completely discussed in the detailed descriptions that follow Figure 2-4.

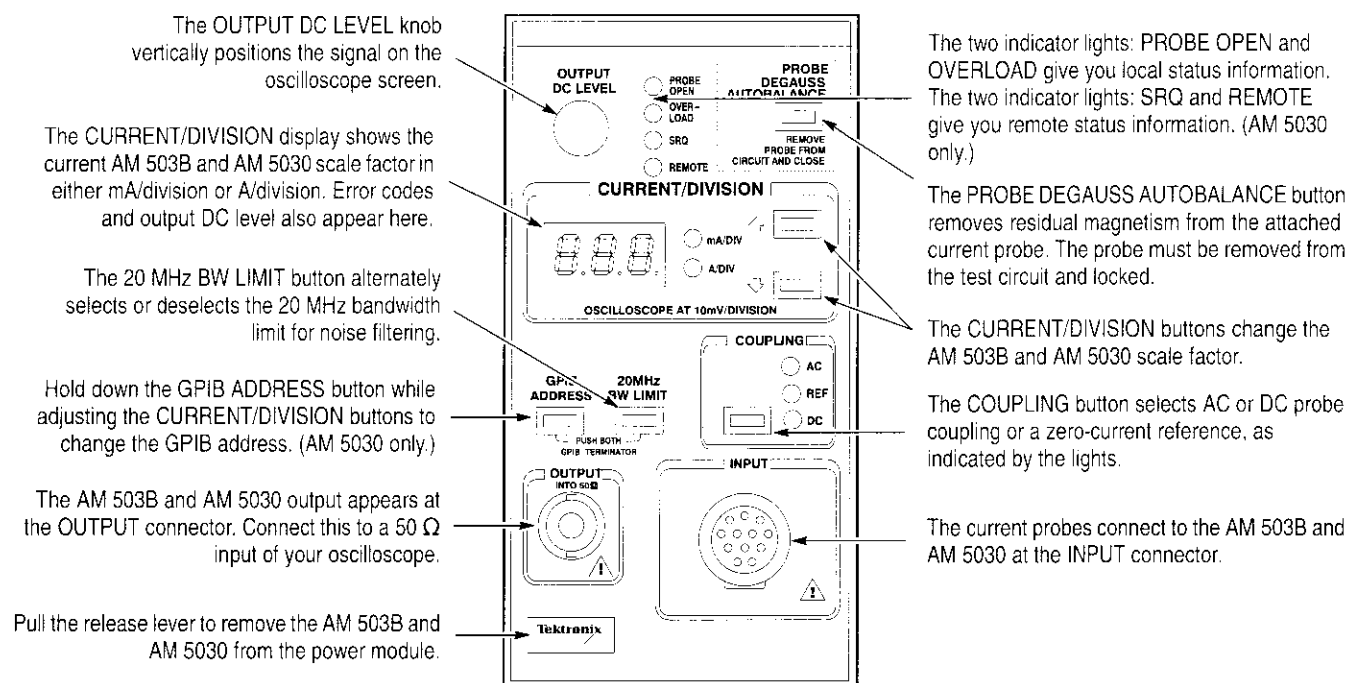

Figure 2-4: The AM 503B and AM 5030 Front Panel

AM 503B and AM 5030 Controls

These front panel controls and indicators are common to both the AM 503B and AM 5030 current probe amplifiers.

OUTPUT DC LEVEL Control

The OUTPUT DC LEVEL knob adjusts the DC offset that appears at the Amplifier OUTPUT connector. The OUTPUT DC LEVEL knob adjusts the displayed waveform relative to ground. After setting a zero-current reference, do not use the oscilloscope vertical position to move the waveform up and down on the display; use the Amplifier OUTPUT DC LEVEL knob instead.

As you adjust the OUTPUT DC LEVEL knob, the display shows you the output level in divisions. When you stop moving the OUTPUT DC LEVEL knob, the display reverts to show current per division.

The PROBE DEGAUSS AUTOBALANCE button will change the output DC level setting if the Amplifier coupling is set to REF. In this case only, the output DC level setting will be reset to ground; otherwise, the DC level setting will remain at its previous setting.

NOTE. *To maintain measurement accuracy, position the signal with the AM 503B and AM 5030 OUTPUT DC LEVEL knob. Do not adjust the vertical position control of your oscilloscope once you have established a zero-current reference.*

PROBE OPEN Indicator

When lit, this indicator informs you that the current probe is unlocked. You must have the probe slide locked in order to degauss the probe or to accurately measure current.

OVERLOAD Indicator

When lit, this indicator informs you that the measurement you are taking exceeds the *continuous* amplitude limit of the AM 503B and AM 5030. The detection circuits only detect low frequency (≈ 10 kHz) and DC overloads. Since overloads can magnetize the probe, you should always degauss the probe after an overload.



WARNING. *To avoid personal injury or equipment damage, do not exceed the specified electrical limits of the AM 503B and AM 5030 or any applicable accessories.*

PROBE DEGAUSS AUTOBALANCE Button

When pressed, this button performs two functions that maximize measurement accuracy. First, the Amplifier generates a degauss signal to remove any residual magnetism from the attached current probe. Second, the Amplifier initiates an operation to remove any undesired DC offsets from its circuitry. During the degauss process, the Amplifier is busy and cannot be used to measure current.

The indicator light in the PROBE DEGAUSS AUTOBALANCE button will blink whenever the Amplifier detects that the current probe needs degaussing or DC balancing. The Amplifier cannot detect all circumstances that require probe degaussing, so you may need to degauss the probe at times when the PROBE DEGAUSS AUTOBALANCE light is not blinking. The blinking light serves as a reminder to degauss the current probe when one of the following conditions occurs:

- The Amplifier has just been turned on with a current probe connected.
- The current probe has been changed.
- The internal temperature of the Amplifier changed by more than 10° C.
- An overload has occurred.

The indicator stays on steady during the time the Amplifier is busy performing the probe degauss functions. When the degauss and autobalance procedure is complete, the indicator light turns off.

To perform the probe degauss/autobalance function, remove the probe from around all conductors (or ensure that the conductor under test has no power), make sure the probe is locked closed, and then press the **PROBE DEGAUSS AUTOBALANCE** button.

The probe degauss/autobalance routine will not work if the current probe is unlocked or disconnected from the Amplifier input. To properly degauss the current probe, remove it from the conductor under test and lock the probe.

If the PROBE DEGAUSS AUTOBALANCE button is pressed while the coupling is set to REF, the Output DC level is reset to ground. If either AC or DC coupling is selected when the PROBE DEGAUSS AUTOBALANCE button is pressed, the DC level is not changed from its previous setting.

NOTE. The Amplifier displays error code 266 when the Amplifier output is not properly terminated into a 50 Ω load. Make sure your Amplifier OUTPUT is connected to an oscilloscope input using a 50 Ω BNC cable, and that the oscilloscope input is set to 50 Ω impedance. See Figure 1-1 on page 1-2 for proper cabling.

If your oscilloscope does not have 50 Ω impedance settings for inputs, you can place a 50 Ω feed-through termination on the oscilloscope input and connect the Amplifier output cable to the termination. Do not place the feed-through termination at the Amplifier end of the BNC connecting cable.

**CURRENT/DIVISION
Buttons**

The CURRENT/DIVISION \uparrow and \downarrow buttons set the scale factor (sensitivity) of the AM 503B and AM 5030 in a 1–2–5 sequence. The setting of this control is displayed on the digital readout and the units indicator. The CURRENT/DIVISION display indicates the Amplifier scale factor only; it is not a current measurement readout. The measurement output is displayed on the oscilloscope.

NOTE. *To maintain accurate measurements, the vertical gain of the oscilloscope must remain at 10 mV/div.*

COUPLING Button

The COUPLING button determines the coupling between the current probe and the AM 503B and AM 5030. Press the COUPLING button repeatedly until the desired indicator lights up. To couple the current probe for DC plus AC measurements, use DC coupling. For AC measurements only, use AC coupling. To establish a zero-current reference, use REF coupling. While using REF coupling, you cannot measure current or view current waveforms.

NOTE. *Even when making AC current measurements, leave the oscilloscope coupling on DC. Change only the Amplifier coupling to AC. Using the oscilloscope AC coupling may cause the Amplifier to exceed its output dynamic range.*

20 MHz BW LIMIT Button

The 20 MHz BW LIMIT button lets you limit the current probe amplifier bandwidth to 20 MHz. This can be useful to remove high-frequency noise. Press the button again to return to full bandwidth. When the button lights, the bandwidth limit is on. System bandwidth depends on the type of current probe you are using. Refer to the specifications table on page 4–3 for the bandwidth limit frequency for your current probe.

Probe Trim Adjust

After the PROBE DEGAUSS AUTOBALANCE routine has been run, the probe and amplifier system will meet all published specifications; however, if you want to improve the tolerance of the system accuracy, or to intentionally offset the accuracy to make up for total system errors, the probe trim adjust routine may be performed.

Probe trim adjust is a multiplicative factor that you can use to adjust the gain of the current amplifier system. You can set this multiplier in increments of 0.001 from 0.750 through 1.250. Probe trim adjust is used for an optional calibration of some current probes. If you are not performing such an adjustment, leave probe trim adjust to the factory-default of unity gain (1.000).

To set probe trim adjust, press and hold the 20MHz BW LIMIT button while pressing and releasing the COUPLING button. Use the \uparrow and \downarrow buttons to

adjust the setting that is displayed in the CURRENT/DIVISION display. When finished, press either the 20MHz BW LIMIT or COUPLING button to restore normal operation.

The display shows the last three significant digits of the display adjust setting; the leading 0, or 1, are omitted. If the first digit displayed is 7, 8, or 9, then the leading digit must be 0. If the first digit displayed is 0, 1, or 2, then the leading digit must be 1.

OUTPUT Connector

The Amplifier current measurement output is accessed at the OUTPUT connector, which should be connected to the oscilloscope input. Attach one end of a 50 Ω BNC cable to this connector and the other end to a 50 Ω vertical input of your oscilloscope. The output impedance of the Amplifier is 50 Ω .

NOTE. To obtain accurate measurements, the input impedance of your oscilloscope must be 50 Ω . Make sure your Amplifier OUTPUT is connected to an oscilloscope input using a 50 Ω BNC cable, and that the oscilloscope input is set to 50 Ω impedance. See Figure 1-1 on page 1-2 for proper cabling.

If your oscilloscope does not have 50 Ω impedance settings for inputs, you can place a 50 Ω feedthrough termination on the oscilloscope input and connect the Amplifier output cable to the termination. Do not place the feedthrough termination at the Amplifier end of the BNC connecting cable.

INPUT Connector

All current probes compatible with the AM 503B and AM 5030 attach at the INPUT connector, which is a 12-pin female connector. For information about connecting a probe, see *Connecting a Current Probe to the AM 503B and AM 5030* on page 1-8.



CAUTION. To avoid equipment damage, turn the TM Series Power Module off before removing or installing a current probe.

Release Lever

The release lever has the Tektronix name printed on it. Pull the release lever to remove the Amplifier from the power module.



CAUTION. To avoid equipment damage, turn the TM Series Power Module off before removing or installing any plug-in unit.

AM 5030 GPIB Controls

These indicators and controls are unique to the AM 5030 and do not appear on the AM 503B front panel.

SRQ Indicator When lit, this indicator informs you that the AM 5030 has requested service from the controller.

REMOTE Indicator When lit, this indicator informs you that the front panel of the AM 5030 is temporarily locked out because the Amplifier is responding to a GPIB command from the controller.

GPIB ADDRESS Indicator The GPIB ADDRESS button has a light in it. When lit, this indicator informs you that the AM 5030 has been addressed by the controller and that communication is taking place.

GPIB ADDRESS Button The GPIB ADDRESS button lets you set the AM 5030 device address. The GPIB controller must use this address to send commands to the Amplifier. To set the GPIB address, press and hold the GPIB ADDRESS button and, while holding it down, use the \uparrow and \downarrow buttons to adjust the address that is displayed in the CURRENT/DIVISION display.

You can set the address from 0 (A00) through 30 (A30). You can also set the Amplifier off line, which disables all communications with the controller. The off line setting is A—.

GPIB Terminator The GPIB ADDRESS and 20MHz BW LIMIT buttons together let you define the AM 5030 GPIB terminator. The terminator may be set to EOI only or EOI followed by LF. To set the GPIB terminator, press and hold the GPIB ADDRESS button, and also press and hold the 20 MHz BW LIMIT button. While holding them down, use the \uparrow and \downarrow buttons to adjust the setting that is displayed in the CURRENT/DIVISION display. The display shows EOI if the terminator is EOI only and LF if the terminator is EOI followed by LF.

GPIB Operation

NOTE. This material applies only to the AM 5030 Programmable Amplifier. The AM 503B does not support a GPIB interface.

You can use a computer to control the AM 5030 and make measurements. With an oscilloscope that also can be programmed, the computer and AM 5030 can form a complete, automated measurement system.

Your computer, also known as the controller, must be capable of operating on a GPIB bus that conforms to IEEE Std 488.1–1987. GPIB cards are available to provide this capability for personal computers.

The TM 5000 Series Power Module has a 24-pin GPIB connector on its rear panel, as shown in Figure 2–5. This connector has a D-type shell and conforms to IEEE Std 488.1–1987.

Attach an IEEE Std 488.1–1987 GPIB cable (see *Optional Accessories* in the *Replaceable Mechanical Parts* section) between this connector and your controller. Figure 2–5 also shows how cables can be stacked together. You can stack a second cable on either the TM 5000 Series Power Module connector or the controller connector, to similarly connect your oscilloscope.

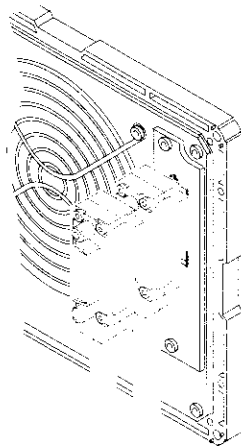

Figure 2–5: Stacked GPIB Connectors

GPIB Requirements

Observe these rules when you use your AM 5030 with a GPIB network:

- Assign a unique device address to each device on the bus. No two devices can share the same device address.
- Do not connect more than 15 devices to the bus.
- Connect one device for every 2 meters (6 feet) of cable used.
- Do not use more than 20 meters (65 feet) of cable for the entire bus.
- Turn on at least two-thirds of the devices on the network while using the network.
- Connect the devices on the network in a star or linear configuration as shown in Figure 2–6. Do not use loop or parallel configurations.

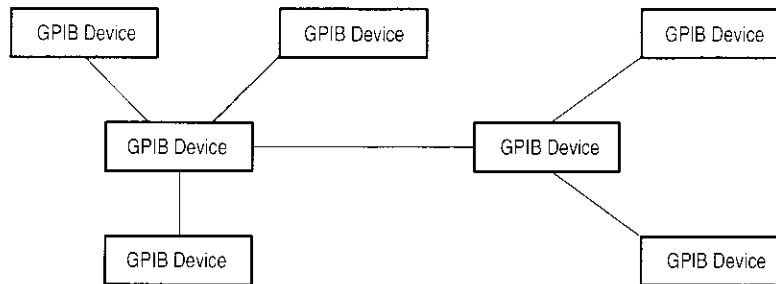

Figure 2–6: Typical GPIB Network Configurations

Setting the GPIB Parameters

You must set the GPIB parameters of the AM 5030 to match the configuration of the bus and controller.

GPIB Address

The GPIB ADDRESS button lets you set the AM 5030 device address. The GPIB controller must use this address to send commands to the AM 5030. The address of the AM 5030 must be different from the addresses used by all other devices on the bus.

To set the GPIB address, press and hold the **GPIB ADDRESS** button and, while holding it down, use the \uparrow and \downarrow buttons to adjust the address that is displayed in the digits. You can set the address from 0 (A00) through 30 (A30). You can also set the AM 5030 off line, which disables all communications with the controller. The off line setting is A—.

GPIB Terminator Pressing both the GPIB ADDRESS and 20MHz BW LIMIT buttons at the same time lets you set the AM 5030 GPIB terminator. The terminator may be set to EOI only or EOI followed by LF. You will need to consult your controller documentation to determine which setting is best for your configuration.

To set the GPIB terminator, press and hold both the **GPIB ADDRESS** and **20MHz BW LIMIT** buttons and, while holding them down, use the ↵ and ⇩ buttons to adjust the setting that is displayed in the digits. The display shows EOI when the terminator is EOI only and LF when the terminator is EOI followed by LF.

Other Documents You Will Need

We cannot know what type of controller you will use with your AM 5030. This document cannot cover the topics that are specific to your installation. To completely understand and implement a GPIB system, you will need the documentation that supports your controller. If you are using a personal computer with a GPIB card, you will need the documentation for both the PC and the GPIB card.

Functional Command Groups

NOTE. This material applies only to the AM 5030 Programmable Amplifier. The AM 503B does not support a GPIB interface.

The AM 5030 GPIB interface commands fall into four groups:

- Front panel commands
- GPIB Status commands
- Amplifier Status commands
- Probe Status commands

Command names show both upper- and lower-case characters. Only the upper-case characters are required. You can abbreviate commands by omitting lower-case characters, starting from the end. For example, you can enter the ALLEve command as ALLEVE, ALLEV, or ALLE.

The AM 5030 is not case-sensitive. You can use lower-case letters anywhere in command names or arguments: alLeVe, AlLEv, or alle are valid.

Front Panel Commands

The commands listed in Table 2-1 are used to control or duplicate the front panel controls and indicators of the AM 5030.

Table 2-1: Front Panel Commands

Command Name	Description
AMPS	Sets output resolution
BWLIMit	Sets or resets bandwidth limiting
COUpling	Sets input coupling
DCLEVel	Adjusts output DC offset (reference) level
DEGAuss	Starts the degauss/autobalance sequence
FPLock	Disables and enables front-panel controls
Overload?	Returns the state of the overload indicator
UNIts?	Returns units of AM 5030 output

GPIB Status Commands

The commands listed in Table 2–2 are used to provide event information and configure the GPIB interface.

Table 2–2: GPIB Status Commands

Command Name	Description
ALLEve?	Returns all pending event codes
ERRor?	Returns the last pending event code
EVEnt?	Returns the last pending event code
EXit	Recovers from an error condition
HELp?	Returns a list of AM 5030 GPIB commands
PATH	Sets whether queries return command names
RQS	Enables or disables system requests (SRQs)
SET?	Returns all AM 5030 settings as command string

Amplifier Status Commands

The commands listed in Table 2–3 are used to identify, configure, and test the AM 5030 amplifier.

Table 2–3: Amplifier Status Commands

Command Name	Description
ID?	Returns instrument ID including firmware version numbers
INIT	Initializes AM 5030 to factory default settings
SERIAL?	Returns AM 5030 serial number
TEST	Performs AM 5030 self test

Probe Status Commands

The commands listed in Table 2–4 are used to adjust and provide information about the probe currently in use.

Table 2–4: Probe Status Commands

Command Name	Description
PROBEOPen?	Returns the state of the probe open indicator
PROBETRim	Sets probe gain adjustment factor
PROBEType?	Returns model of current probe being used

Commands

This section supports the GPIB commands with command definitions, syntax, return messages, and examples.

ALLEve? (Query Only)

Returns a comma-delimited list of up to 41 pending event codes. If no event is pending, it returns the code for "no events to report."

Syntax ALLEve?

Returns ALLEVE <number> [, <number>]

ALLEve? only produces meaningful results when RQS is off. When RQS is on, ALLEve? operates the same as EVent?, except that the returned header is ALLEVE instead of EVENT.

Examples ALLE?
might return 266, indicating that the degauss/autobalance routine has failed because the AM 5030 OUTPUT is not terminated into 50 Ω .

AMPS

Sets or queries the resolution of the AM 5030.

Syntax AMPS <number>
AMPS?

Arguments <Number> is in amperes per division, and should represent a valid setting for the probe being used. Numbers will be rounded to the nearest setting in a 1–2–5 sequence.

Examples AMPS 0.005
sets the resolution of the AM 5030 to 5 mA/division.

AMPS?
might return AMPS 5E–3, indicating that the AM 5030 resolution of the AM 5030 is 5 mA/division.

BWLIMit

Sets or queries the 20 MHz bandwidth limit switch.

Syntax BWLIMit ON
BWLIMit OFF
BWLIMit?

Arguments ON turns bandwidth limiting on; OFF turns bandwidth limiting off.

Examples BWLIM ON
turns on bandwidth limiting.

BWLIM?
might return BWLIMIT OFF, indicating that bandwidth limiting is off.

COUpling

Sets or queries the input coupling of the AM 5030.

Syntax COUpling AC
COUpling DC
COUpling REF
COUpling?

Arguments AC sets the input to AC coupling. DC sets the input to DC coupling. REF sets the input to ground reference.

Examples COU DC
sets the AM 5030 input to DC coupling.

COU?
might return COUPLING REF, indicating that the AM 5030 input is set to ground reference.

DCLEVel

Sets the DC offset level of the AM 5030. This is the current level that will be displayed at the oscilloscope ground reference level. This programming command is the most accurate means to set the DC offset level; the front panel OUTPUT DC LEVEL control is less precise.

Syntax DCLEVel <number>
DCLEVel?

Arguments <Number> specifies the offset in amperes. The value may range ± 10 times the sensitivity (AMPS) setting. For example, if the current AMPS setting is 1 A/div, the valid range of the DCLEVel is from -10 A to 10 A.

Examples DCLEV 0.1
sets the DC offset level to 0.1 A.

DCLEV?
might return 1, indicating that the DC offset level is currently 1 A.

DEGAuss (No Query Form)

Initializes the probe degauss/autobalance sequence.

Syntax DEGAuss
DEGAuss 0
DEGAuss 1
DEGAuss 2

Arguments If the argument is omitted or is zero, the command operates like the front panel PROBE DEGAUSS AUTOBALANCE button; it recalibrates gain only if a significant temperature change has occurred since the last calibration.

An argument of 1 forces a gain calibration, even if it would normally be bypassed because of insufficient temperature change since the last calibration.

An argument of 2 performs a gain calibration only, without balancing the Hall device. This is used when adjusting the A6302 and A6302XL current probe DC offset adjustment. See page 6-4.

Examples DEGA
operates just like pressing the PROBE DEGAUSS AUTOBALANCE button.

ERRor? (Query Only)

Returns the error or event code for the most recent event reported by serial poll, or for the highest priority condition pending.

ERRor? and EVent? function identically.

Syntax ERRor?

Returns The most recent error/event code.

Examples ERR?
might return 266 as the most recent error code.

EVent? (Query Only)

Returns the error or event code for the most recent event reported by serial poll, or for the highest priority condition pending.

EVent? and ERRor? function identically.

Syntax EVent?

Returns The most recent error/event code.

Examples EV?
might return 266 as the most recent error code.

EXit

Causes the AM 5030 to exit a test mode or recover from an error condition.

Syntax EXit

FPLOCK

Enables and disables the front panel buttons. When locked, the AM 5030 front panel buttons and knob are completely inoperative.

Syntax FPLOCK ON
FPLOCK OFF
FPLOCK?

Arguments ON turns on the front panel lock, which disables buttons and knob. OFF restores operation of the buttons and knob.

Examples FPL OFF
restores the operation of the front panel buttons and knob.

FPL?
might return ON, indicating that the front panel buttons and knob are inoperative because they are locked.

HELP? (Query Only)

Returns a list of commands that are recognized by the AM 5030.

Syntax HELP?

Returns Will always return the string HELP ALLEVE, AMPS, BWLIMIT, COUPLING, DCLEVEL, DEGAUSS, ERROR, EVENT, EXIT, FPLOCK, HELP, ID, INIT, OVERLOAD, PATH, PROBEOPEN, PROBETRIM, PROBETYPE, RQS, SERIAL, SET, TEST, UNITS

ID? (Query Only)

Returns the AM 5030 identification, including the name, Codes & Formats version, main board firmware version, and GPIB board firmware version.

Syntax ID?

Returns The instrument identification string.

Examples ID?
 may return the string ID TEK/AM 5030, V81.1, MAIN/1.0, GPIB/1.0.

INIT (No Query Form)

Initializes the AM 5030 to factory default settings.

- COUPLING is set to GROUND
- Amps/division is set to minimum for attached probe
- BW LIMIT is set to OFF.
- DC LEVEL is set to 0 (zero)
- The degauss lamp will flash (if probe is connected) indicating that a probe degauss is required

PROBETrim settings are not changed.

Syntax INIT

Overload? (Query Only)

Returns the status of the overload indicator (the front panel OVERLOAD light).

Syntax Overload?

Returns OVERLOAD ON
 OVERLOAD OFF

Examples OV?
 might return OVERLOAD ON, indicating an overload condition has occurred.

PATH

Controls whether queries return the command header (the command name) along with the returned data. With PATH off, BWLIMIT? might return ON. With PATH on, the same query would return BWLIMIT ON.

The PATH command does not affect the data returned from SET?, which will always return command headers. This is because the reply to SET? must always be able to be sent as a command string to the AM 5030.

Syntax PATH ON
PATH OFF
PATH?

Arguments ON turns header return on. OFF prevents the inclusion of command name headers in query return strings other than SET?.

Examples PATH OFF
eliminates headers (command names) from query return strings.

PATH?
might return OFF to indicate that headers are removed from query return strings, or PATH ON to indicate that headers are included in query return strings.

PROBEOPen? (Query Only)

Returns the status of the probe open indicator (the front panel PROBE OPEN light).

Syntax PROBEOPen?

Returns PROBEOPEN ON
PROBEOPEN OFF

Examples PROBEOP?
might return PROBEOPEN ON, indicating that the probe is not locked shut.

PROBETrim

Lets you specify a multiplicative gain factor (trim adjustment) for probe compensation. There is a trim adjustment value for each type of probe (for example, A6302, A6302XL, A6303, A6303XL, or A6304XL). This command will set or query only the trim adjustment for the type of current probe currently connected to the AM 5030. If no probe is connected, executing this command or query will cause error 264, "No probe connected."

Probe trim is used to perform an optional fine-tune calibration of the A6303 Current Probe

Syntax PROBETrim <number>
 PROBETrim?

Arguments <number> is a multiplicative gain factor, in the range 0.750 to 1.250 in increments of 0.001. The probe input will be multiplied by this gain factor.

Examples PROBETR 1
 sets the trim adjustment to unity for the type of probe currently connected to the AM 5030.

 PROBETR?
 might return PROBETRIM 1.1, indicating that the probe trim adjustment is currently set to 1.1 for probes of the type of probe currently connected to the AM 5030.

PROBEType? (Query Only)

Returns the type (model) of current probe connected to the AM 5030 INPUT connector. The return string NOPROBE indicates that no current probe is connected.

Syntax PROBEType?

Returns PROBETYPE A6302
 PROBETYPE A6303
 PROBETYPE A6302XL
 PROBETYPE A6303XL
 PROBETYPE A6304XL
 PROBETYPE NOPROBE

Examples PROBETY?
 might return PROBETYPE A6303, indicating that a A6303 Current Probe is attached to the INPUT connector of the AM 5030.

RQS

Enables or disables SRQs (System Requests). When disabled, the AM 5030 does not act on error conditions other than to log them, and does not signal that it is ready to transmit data to the controller.

Syntax RQS ON
 RQS OFF
 RQS?

Arguments ON enables SRQ events. Off disables SRQ events.

Examples RQS ON
 enables SRQ events.

SERIAL? (Query Only)

Returns the serial number of the AM 5030.

Syntax SERIAL?

Returns The instrument serial number as an ASCII string. The serial number is an eight digit string, always starting with a space (ASCII 32) character.

Examples SERIAL?
might return SERIAL B018607.

SET? (Query Only)

Returns a string containing all the individual programming commands required to return the AM 5030 to its present state. This string can be saved and sent at some future time when you want to return the AM 5030 to all the present settings.

Because this string is intended to be sent back to the AM 5030, the return string contains command headers (names) regardless of the setting of the PATH command.

Syntax SET?

Returns AMPS <number>; BWLIMIT <OFF | ON>; COUPLING <AC | DC | REF>;
DCLEVEL <number>; FPLOCK <ON | OFF>; PATH <ON | OFF>; PROBETRIM
<number>; RQS <ON | OFF>;

Examples SET?
might return AMPS 1.0; BWLIMIT OFF; COUPLING DC; DCLEVEL 0.5;
FPLOCK OFF; PATH ON; PROBETRIM 1.000; RQS ON;.

TEST (No Query Form)

Instructs the AM 5030 to perform a self-test operation and return the error code of the first error that occurs. If no error occurs, TEST will return 0.

Syntax	TEST
Returns	<number>
Examples	TEST might return TEST 0, indicating that the self-test completed successfully with no errors. TEST might return TEST 357; low battery.

UNIts? (Query Only)

Returns the output units of the AM 5030. Normally, these will be amperes whenever a current probe is connected to the AM 5030 OUTPUT. Whenever a voltage adapter or loop-through adapter is connected (both are calibration fixtures), the units will be volts.

Syntax	UNIts?
Returns	UNITS A UNITS V
Examples	UNI? might return A, indicating that a current probe is connected to the AM 5030 OUTPUT connector, and the output units are amperes.

Error Messages & Codes

NOTE. This material applies primarily to the AM 5030 Programmable Amplifier. Event Codes displayed on the front panel apply also to the AM 503B.

These are the event codes (also known as error codes) that the AM 5030 can generate, along with their meaning. Some of these codes may also appear on the front panel in the CURRENT/DIVISION readout.

Table 2-5: AM 5030 Event Codes

Error Number	Displayed on Front Panel	Description of Error
0	No	Null event. Reported when RQS is ON and EVent?, ERRor?, or ALLEve? is attempted prior to reading the serial poll status byte.
101	No	Invalid GPIB command.
154	No	Invalid number in GPIB command.
155	No	Invalid quoted string. String may be more than 128 characters, be terminated with EOI (or LF if terminator is set to EOI and LF), or contain an ASCII NUL (0).
156	No	Invalid GPIB command.
157	No	Syntax error.
160	No	Expression too complex.
203	No	I/O buffers full, so output buffer was dumped. This may happen if you send a sequence of queries without talk-addressing the AM 5030.
250-251	No	Invalid GPIB command.
252	No	AMPS argument out of range. Command not executed.
253	No	DCLEVel argument out of range. Command not executed.
254-256	No	Invalid GPIB command.
257	No	PROBETRim argument out of range. Command not executed.
258-260	No	Invalid GPIB command.
261	No	DEGAuss argument out of range. Command not executed.
262	No	Invalid GPIB command.
263	Yes	Probe opened during degauss/autobalance.
264	No	No probe attached to INPUT connector. This can also occur if a current probe is defective.
265	No	Probe open when degauss/autobalance initiated.
266	Yes	The Amplifier OUTPUT was not terminated into 50 Ω . It can also be caused by faulty hardware.
267	Yes	Internal buffer overflow.
268	No	Invalid GPIB command.

Table 2–5: AM 5030 Event Codes (Cont.)

Error Number	Displayed on Front Panel	Description of Error
350	Yes	Amplifier needs repair. Cannot EXit from this error.
351–354	Yes	Amplifier needs repair.
355	Yes	NVRAM failure, Amplifier reset to factory default. Will occur first power up after new firmware has been installed.
356	Yes	Amplifier needs repair.
357	Yes (displayed as L0)	Internal battery is weak and needs replacement.
358	Yes	An error occurred while the AM 5030 was restoring previously-saved settings.
359	Yes	Probe needs repair; AM 5030 cannot recognize the probe type.
360–362	Yes	Amplifier needs repair.
363–364	Yes	Amplifier or probe needs repair.
400	No	AM 5030 function normal, no events to report.
401	No	Power on has occurred.
450	No	Degauss/autobalance complete.
550–594	Yes	Error occurred during internal automatic adjustment. Repeated errors in the range 550–594 indicate the Amplifier needs repair. 580 and 581 indicate that the Amplifier was unable to complete a probe offset adjustment. See the DC Offset Adjustment procedure for the particular probe you are using.
650	No	Timer indicates too long since last degauss; probe should be degaussed. PROBE DEGAUSS AUTOBALANCE light will blink until probe degaussed.
651	No	Probe overload occurred; probe should be degaussed. PROBE DEGAUSS AUTOBALANCE light will blink until probe degaussed.
652–653	No	The automatic Hall-device biasing circuit is at the end of its compensation range; probe should be degaussed. PROBE DEGAUSS AUTOBALANCE light will blink until probe degaussed.



Reference

Reference Notes

These notes are provided to help you realize the full potential of the AM 503B and AM 5030 current probe systems.

Degaussing a Probe with an Unpowered Conductor in the Jaws

Under almost all conditions, you can degauss your current probe while a conductor of an unpowered circuit is clamped in the jaws. The advantage of degaussing with an unpowered circuit is that any offset from stray DC magnetic fields are compensated. In an automated environment, degaussing with the conductor in the probe jaws eliminates the need to manually remove the probe.

NOTE. *Be certain that the conductor in the probe jaws is completely unpowered. Any current flowing through the conductor will cause a residual offset in the current probe, and the Amplifier may fail calibration.*

If the impedance of your circuit is higher than that shown in Table 3–1, the degauss procedure will succeed because the Amplifier will be able to saturate the probe core. While degauss occurs, the probe will induce a voltage in the unpowered circuit. This also appears in Table 3–1. Your circuit must be able to absorb this induced voltage. With low impedance circuits, several amperes may be induced in the circuit being measured. This may be of concern when you are using very small conductors.

Table 3–1: Unpowered Circuit Degauss Limits

Probe Type	Minimum Circuit Resistance	Maximum Induced Voltage
A6302	10 m Ω	40 mV at 200 Hz
A6303	5 m Ω	30 mV at 200 Hz
A6302XL	10 m Ω	40 mV at 200 Hz
A6303XL	5 m Ω	30 mV at 200 Hz
A6304XL	1 m Ω	15 mV at 100 Hz

Bandwidth Limiting

You can reduce the apparent noise on a current waveform by pressing the 20MHz BW LIMIT button on the AM 503B and AM 5030. You can also use the bandwidth limiting of your oscilloscope.



WARNING. Do not exceed the specified bandwidth limits of your current probe. Measuring frequencies in excess of the specified limit can cause the probe to overheat severely, resulting in personal injury or damage to the equipment. Refer to the probe Instructions for frequency derating.

Measuring Differential Current

You can place two conductors in a current probe to provide differential or null current measurement. This avoids the necessity of using two current measurement systems with a differential oscilloscope amplifier.

1. Orient the two conductors under test so that the polarities oppose each other. Clamp the current probe around the two conductors as shown in Figure 3-1.
2. Measure the current. A waveform above the baseline indicates the conductor with the conventional current flow in the direction of the probe arrow is carrying the greater current. Conventional current flows from positive to negative.
3. To adjust for a current null, adjust the current in one of the conductors until the displayed measurement is zero.

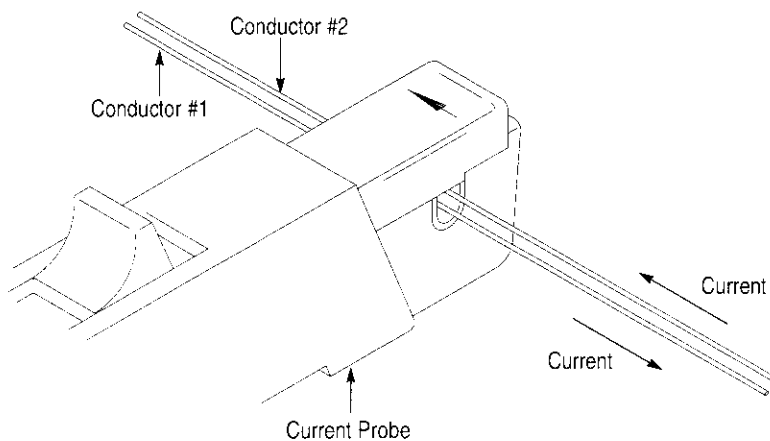

Figure 3-1: Measuring Differential Current and Nulls

AC and DC Coupling

You can couple the signal input to the AM 503B and AM 5030 with either DC or AC coupling. DC coupling shows the DC and AC measurement components while AC coupling removes the DC component from the displayed signal. When you use AC coupling, make sure that the input DC current does not exceed the probe specifications.

AC coupling will affect waveforms at frequencies higher than the AC Coupling Low-Frequency Bandwidth. For example, pulsed currents may exhibit rolloff or decreased amplitude. Figure 3–2(a) shows a low-frequency square wave using AC coupling. The signal exhibits low-frequency rolloff. By changing the Amplifier coupling to DC, the pulse is displayed as truly square, as shown in Figure 3–2(b).



Figure 3–2: Effect of AC or DC Coupling on Low-Frequency Signals

If you are trying to examine a low-frequency signal that is superimposed on a comparatively large DC component, you can resolve the signal by performing these steps:

1. Press the **COUPLING** button on the Amplifier repeatedly until the **AC** light goes on.
2. Adjust the **CURRENT/DIVISION** controls on the Amplifier so that the signal shows maximum detail without going off the oscilloscope screen.
3. Press the **COUPLING** button of the Amplifier repeatedly until the **DC** light goes on. Center the DC component on the zero-current line by adjusting the **OUTPUT DC LEVEL** control of the Amplifier. The signal trace on the oscilloscope will move up and down as the control is adjusted.

NOTE. Even when making AC current measurements, leave the oscilloscope coupling on DC. Change only the Amplifier coupling to AC. Using the oscilloscope AC coupling may cause the Amplifier to exceed its output dynamic range.

Maximum Current Limits

Current probes have three maximum current ratings: continuous, pulsed, and Ampere-second product. Exceeding any of these ratings can saturate the probe core, magnetizing the core and causing measurement errors. *Specifications* in the probe Instructions lists the maximum current ratings of compatible probes.

- Maximum Continuous Current refers to the maximum current that can be continuously measured at DC or at a specified AC frequency. The maximum continuous current value is derated with frequency; as the frequency increases, the maximum continuous current rating decreases.
- Maximum Pulsed Current refers to the maximum peak value of pulsed current the probe can accurately measure, regardless of how short (within bandwidth limitations) the pulse duration is.
- Ampere-Second Product defines the maximum width of pulsed current that you can measure when the pulse amplitude is between the maximum continuous and maximum pulsed current specifications. The maximum continuous specification itself varies by frequency.

NOTE. Always degauss the probe after measuring a current that exceeds the maximum continuous current, maximum pulsed current, or Ampere-second product rating of the probe. Exceeding these ratings can magnetize the probe and cause measurement errors.

To determine if your measurement exceeds the Ampere-second product, perform either Procedure A or Procedure B.

Procedure A

To determine the maximum allowable pulse width, measure the peak current of the pulse (see Figure 3–3a). Divide the Ampere-second (or Ampere-microsecond) specification of your probe by the measured peak current of the pulse. The quotient is the maximum allowable pulse width; the pulse width at the 50% point of the measured signal must be less than this value.

For example, the A6302 Current Probe has a maximum Ampere-second product of 100 A · μ s. If a pulse measured with an A6302 has a peak current of 40 A, the maximum allowable pulse width would be 100 A · μ s divided by 40 A, or 2.5 μ s.

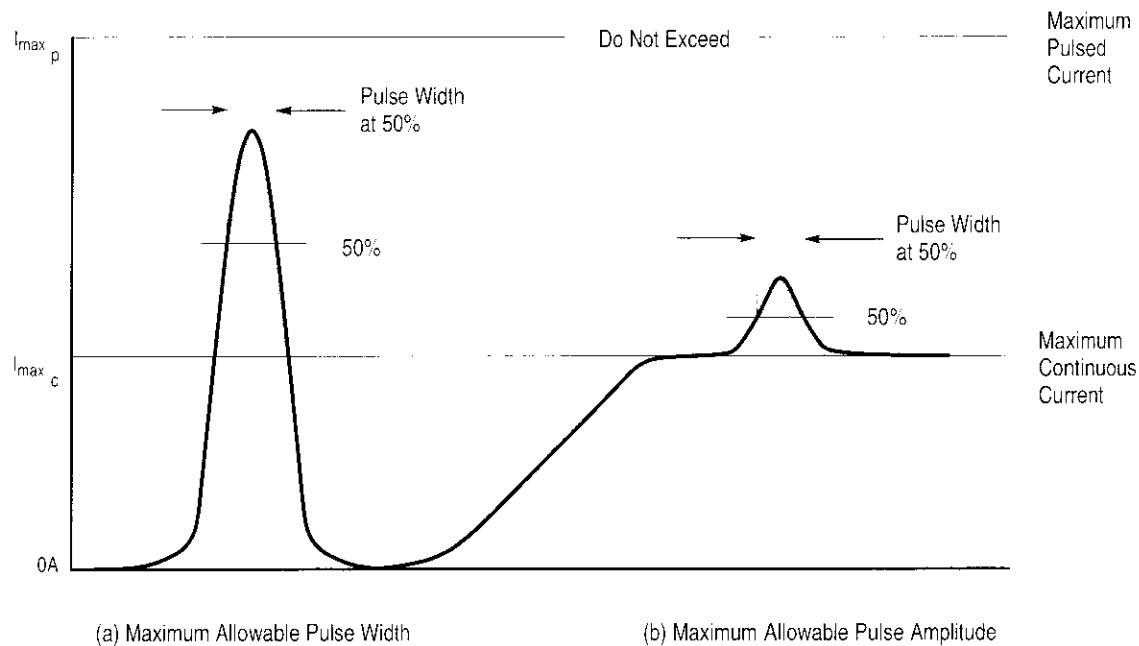

Figure 3-3: Applying the Amp-Second Product Rule

Procedure B To determine the maximum allowable pulse amplitude, measure the pulse width at the 50% points (see Figure 3-3b). Divide the Ampere-second (or Ampere-microsecond) specification of your probe by the pulse width. The quotient is the maximum allowable current; the peak amplitude of the measured pulse must be less than this value.

For example, the A6302 Current Probe has a maximum Ampere-second product of $100 \text{ A} \cdot \mu\text{s}$. If a pulse measured with an A6302 probe has a width of $3 \mu\text{s}$, the maximum allowable peak current would be $100 \text{ A} \cdot \mu\text{s}$ divided by $3 \mu\text{s}$, or 33.3 A .

Extending Current Range

You may encounter situations where your measurement exceeds the maximum current rating of the connected probe. This section discusses methods for extending AC and DC current ranges without exceeding specified limits.



WARNING. To avoid personal injury or equipment damage, do not exceed the specified electrical limits of the AM 503B and AM 5030 or any applicable accessories. When using multiple conductors, do not exceed current limits on either conductor.

Extending DC Range

If you want to measure a low-amplitude AC component that is superimposed on an extremely large steady state DC component (such as in a power supply), or if you want to extend the DC current range of your probe, you can add offset (bucking) current with a second conductor.

To supply additional bucking current, place a second conductor that has a pure DC component of known value in the probe jaw with the conductor under test, as shown in Figure 3-4(a). Orient the second conductor so that the bucking current flows in the opposite direction of the DC flow in the conductor under test.

You can increase the value of the bucking current by winding multiple turns of the second conductor around the probe, as shown in Figure 3-4(b). The bucking current is equal to the current flowing in the conductor, multiplied by the number of turns wound around the probe. For example, if the second conductor has a current of 100 mA DC and is wrapped around the probe five times, the DC bucking current is 100 mA multiplied by 5, or 500 mA DC.

To determine measurement values, add the value of the bucking current to the displayed measurement.

NOTE. Adding a second conductor to the probe increases the insertion impedance and reduces the upper bandwidth limit of the probe. Winding multiple turns further increases the insertion impedance, further reducing the upper bandwidth limit.

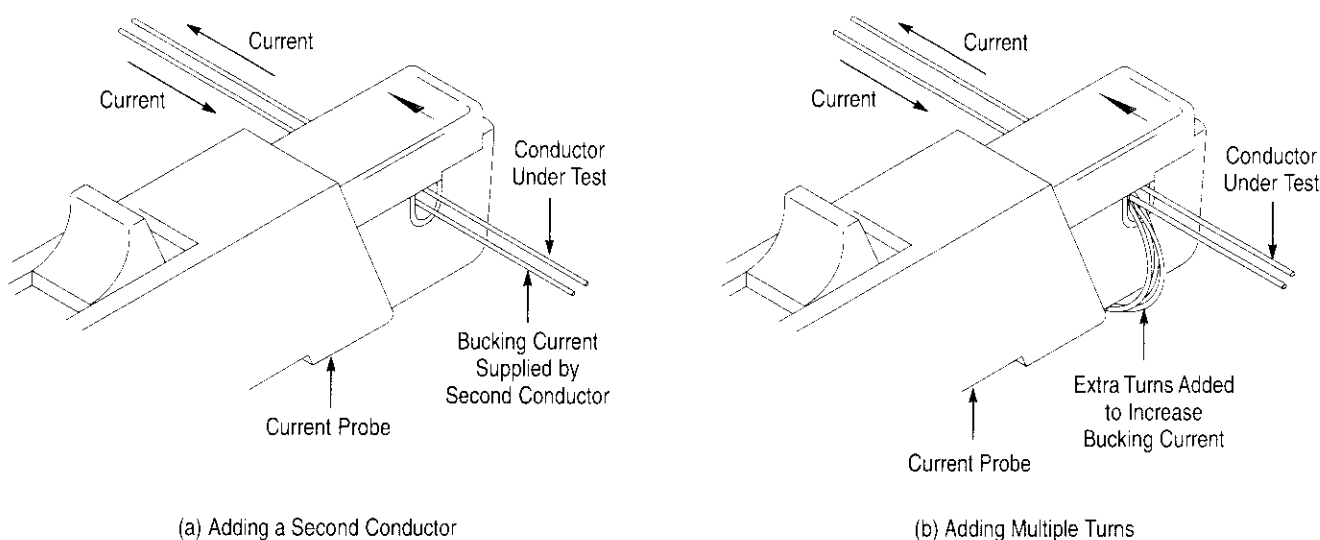

Figure 3-4: Increasing the DC Measurement Range

Extending AC Range

You can extend the AC amplitude limit of the AM 503B and AM 5030 by using the Tektronix CT-4 High-Current Transformer. The CT-4, designed for use with the A6302 or A6302XL current probes, extends the current probe range by a factor of 20:1 or 1000:1. The CT-4 can provide external steady-state DC bucking current up to 300 A. For more information about the CT-4, consult your Tektronix sales representative.

Because the CT-4 has a lower AC bandwidth limit than the A6302 or A6302XL, set the Amplifier coupling to DC when using the CT-4.

Increasing Sensitivity

If you are measuring DC or low-frequency AC signals of very small amplitudes, you can increase measurement sensitivity of your Current Probe by winding several turns of the conductor under test around the probe as shown in Figure 3-5. The signal is multiplied by the number of turns around the probe.

When viewing the signal on the oscilloscope screen, divide the displayed amplitude by the number of turns to obtain the actual current value. For example, if a conductor is wrapped around the probe five times and the oscilloscope shows a reading of 5 mA DC, the actual current flow is 5 mA divided by 5, or 1 mA DC.

NOTE. Winding multiple turns around the probe increases insertion impedance and reduces the upper bandwidth limit of the probe.

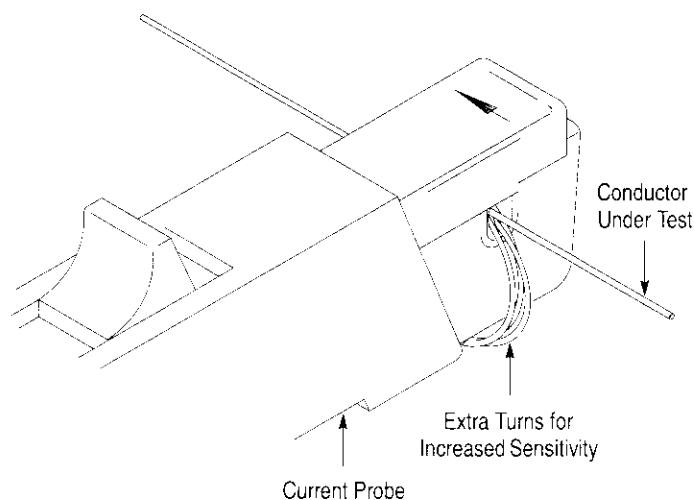

Figure 3-5: Increasing Probe Sensitivity

Application Notes

This section describes some of the typical measurement applications of the AM 503B and AM 5030 Current Probe Amplifiers:

- Automobile Charging Systems
- Inductance Measurements
- Continuity Test of Multiple-Conductor Cable
- Measuring Inductor Turns Count

Automobile Charging Systems

Most automotive charging systems are three-phase alternators with a diode rectifier network. A meter averages current from all three phases, and cannot detect a single-phase diode problem. Observing the charge current waveform can quickly reveal if one diode is shorted or open.

The diagram in Figure 3–6 shows the equipment setup. Refer to Table 3–2 for the test equipment setup. An A6303 Current Probe was used for this high-current, low-voltage application. The A6303 is degaussed and clamped around the positive battery lead from the alternator. The probe arrow is pointed away from the alternator and toward the battery side of the circuit, to reflect conventional current. The automobile is started and the lights are turned on to add a significant load to the circuit.

Table 3–2: Automobile Charging Systems Test Setup

Instrument	Control	Setting
AM 503B and AM 5030	COUPLING	DC
	OUTPUT DC LEVEL	0 V (oscilloscope ground reference line)
	CURRENT/DIVISION	10 A
	20MHz BW LIMIT	off
Oscilloscope	Coupling	DC
	Volts/Division	10 mV
	Zero-Current Reference	Center graticule line
	Time Base	200 μ s/division

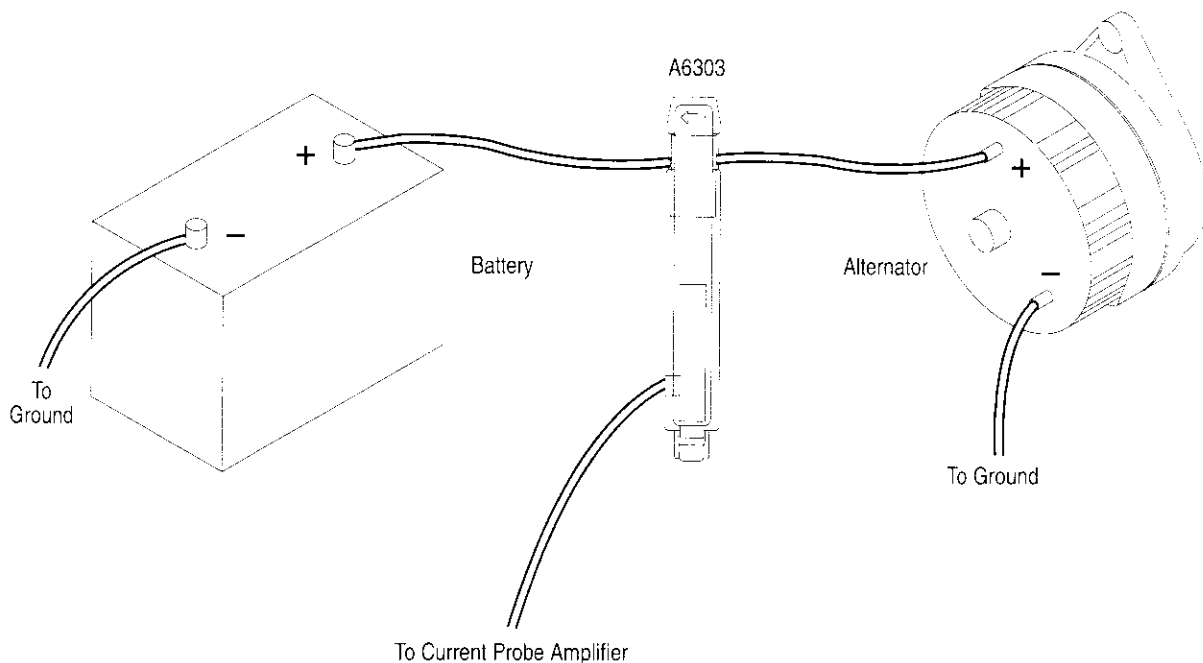

Figure 3-6: Setup for Measuring Charging Current

The waveform in Figure 3-7(a) shows the three-phase ripple frequency. The average charge current is approximately 27 A with a minimum peak of approximately 23 A and a maximum peak of approximately 31 A. The waveform shows a continuous cycle with no dropouts, so the alternator circuit appears to be functioning properly. A single-phase diode failure normally appears as an extreme drop in charge current every third cycle, as shown in Figure 3-7(b).

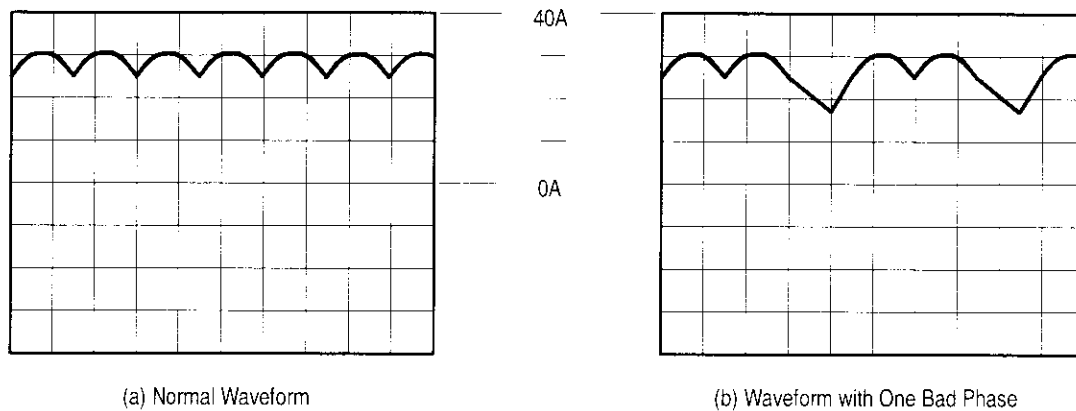

Figure 3-7: Charge Current Waveforms

Inductance Measurements

You can use the AM 503B and AM 5030 to measure inductance of coils. Two different methods can be used: one for low-impedance pulse sources and another for high-impedance pulse sources of known value.

Low-Impedance Pulse Sources

Figure 3–8 shows a measurement setup using a constant-voltage pulse generator of extremely low output impedance. The inductor is connected across the output terminals of the pulse source. The current probe is attached to one of the source leads and the current ramp is measured.

The inductance is effectively defined by the slope of the current ramp, shown in Figure 3–9, and is mathematically expressed by the following formula:

$$L = \frac{-E}{\frac{di}{dt}}$$

where L is the inductance in henries, E is the voltage of the pulse generator, dt is the change in time, and di is the change in current.

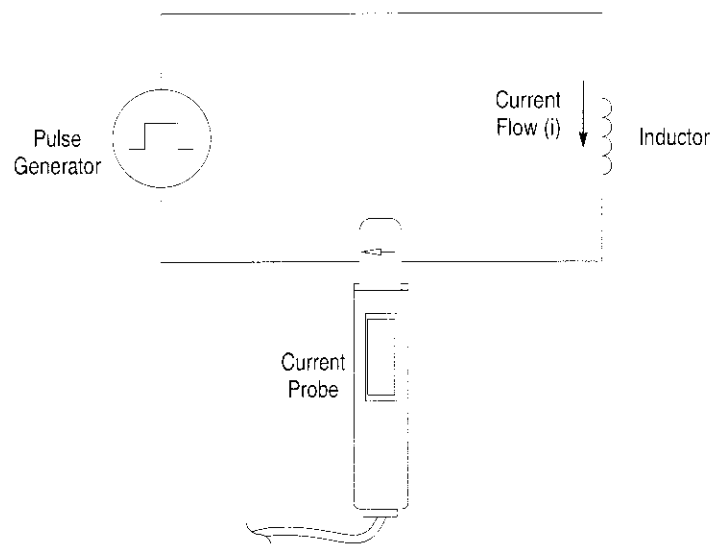

Figure 3–8: Measuring Inductance with a Low-Impedance Source

NOTE. If the probe impedance is a significant part of the total circuit inductance, measurement accuracy will be affected. Refer to the probe specifications for probe insertion impedance.

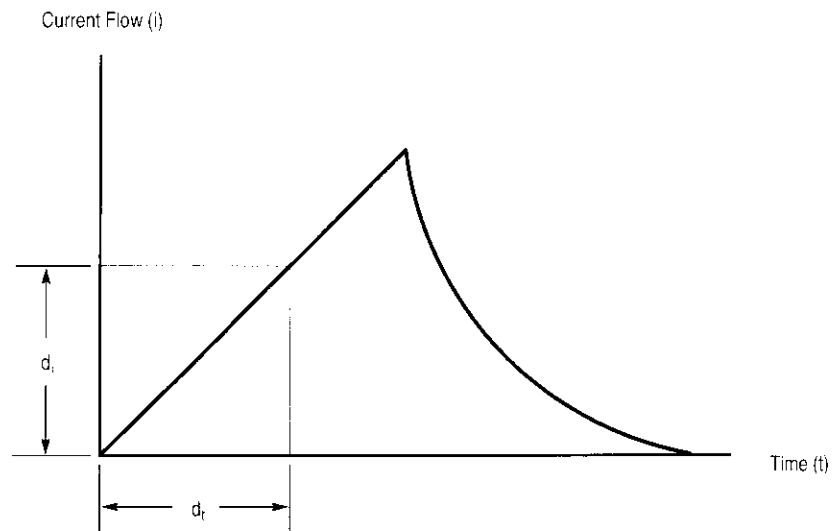

Figure 3-9: Linear Current vs. Time Ramp

High-Impedance Pulse Sources

If the pulse source has a higher impedance of known resistance, such that the output voltage drops as the current increases, the inductance of a coil can be calculated by the time constant of the charge curve. Figure 3-10 shows the setup diagram, which is similar to the previous example. The current ramp represented in Figure 3-11 shows how the values for the inductance formula are obtained.

Use this formula to calculate the inductance based on the current measurement:

$$L = \tau R$$

where L is the inductance in henries, τ is the time required for the current to rise or fall 63.2% of the total current value, and R is the source resistance of the pulse generator.

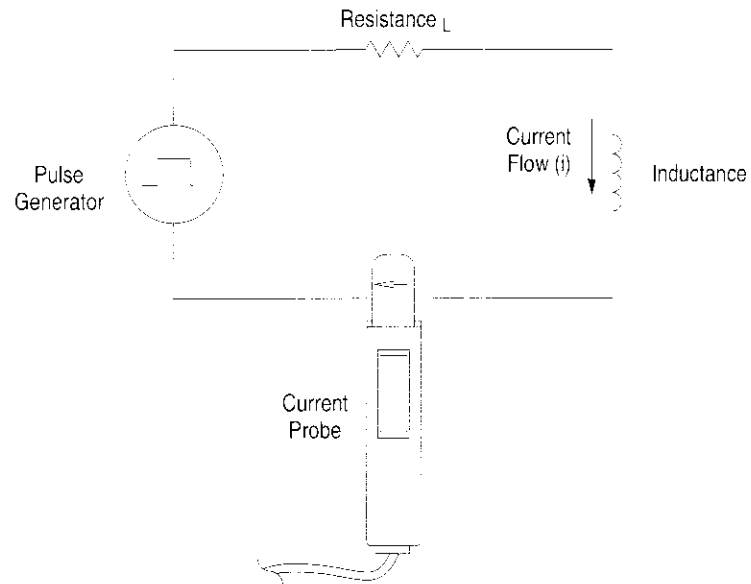

Figure 3–10: Measuring Inductance with a High-Impedance Source

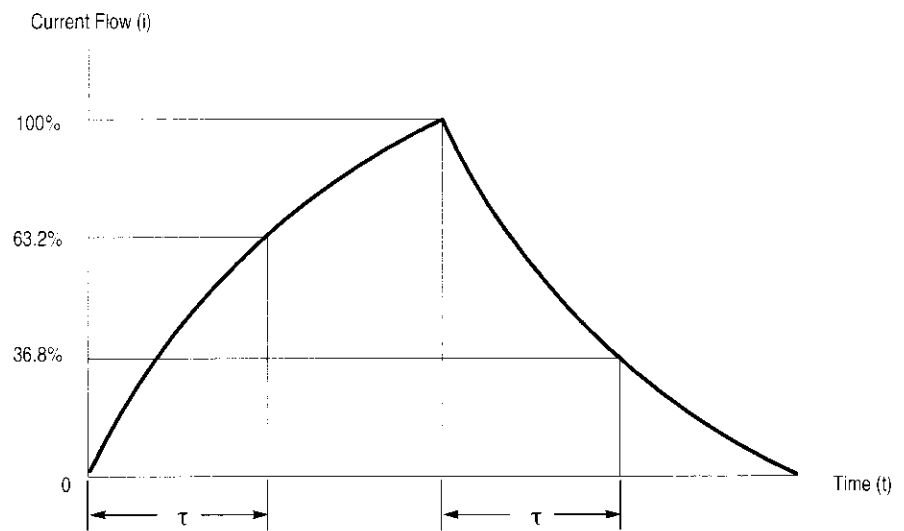

Figure 3–11: High-Impedance Source Current Ramp

Continuity Test of Multiple-Conductor Cable

Single conductors in a multiconductor cable can be tested with the AM 503B and AM 5030. To check a conductor, clamp the current probe around the cable bundle and check for a specific, known current signal. If there is no current or the current is abnormally low, then the conductor has a continuity problem. If the current is abnormally high, then the conductor may have a short to ground.

Measuring Inductor Turns Count

To obtain an approximate turns count of an inductor, connect the inductor to a current limited source, as shown in Figure 3–12. Measure the input current on one of the inductor leads, then clamp the current probe around the inductor and note the current value. The number of turns is equal to the ratio of coil current to input current. The accuracy of this method is limited by the current measurement accuracy. The following method allows more precise turns measurement.

For a more precise turns count, you need a coil with a known number of turns to use as a reference. The measurement setup is similar to the previously described one, except the reference coil and the test coil are inserted into the current probe so that the currents oppose each other (see Figure 3–13). You must observe the polarity of coil current to determine whether the test coil has more or fewer turns than the reference coil. The turns are calculated by using the formula:

$$N_2 = N_1 \times \frac{I_m}{I_i}$$

where N_2 is the number of turns in the test coil, N_1 is the number of turns in the reference coil, I_m is the measured coil current, and I_i is the input current.

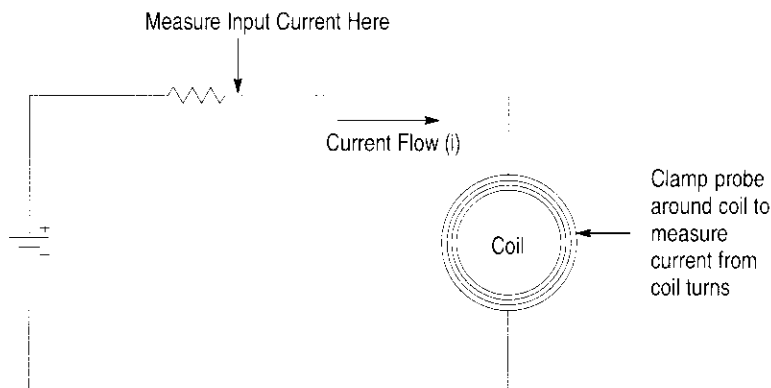

Figure 3–12: Measuring the Number of Turns in a Coil

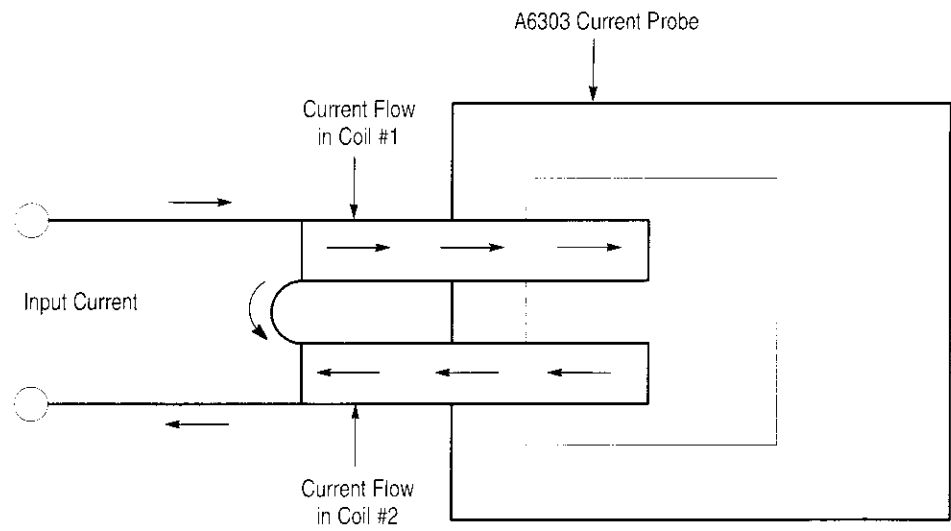

Figure 3-13: Turns Measurement Using Reference Coil

Error Codes

During normal operation, the CURRENT/DIVISION readout of the AM 503B and AM 5030 displays the scale factor or other setting such as the GPIB address. If an instrument failure occurs, the display will flash an error code number.

Error Code 266 The Amplifier displays error code 266 when the Amplifier output is not properly terminated into a 50 Ω load. Make sure your Amplifier OUTPUT is connected to an oscilloscope input using a 50 Ω BNC cable, and that the oscilloscope input is set to 50 Ω impedance. See Figure 1-1 on page 1-2 for proper cabling.

If your oscilloscope does not have 50 Ω impedance settings for inputs, you can place a 50 Ω feedthrough termination on the oscilloscope input and connect the Amplifier output cable to the termination. Do not place the feedthrough termination at the Amplifier end of the BNC connecting cable.

Error Code LO When the internal backup battery becomes weak, the CURRENT/DIV display will momentarily flash the characters LO when the instrument is turned on. For battery replacement instructions, refer to Battery Replacement on page 7-10.

NOTE. *If a battery low condition occurs, calibration values in NVRAM may be lost, which can cause the the AM 503B and AM 5030 to fail to meet specifications.*

Other Error Codes If an error code other than 266 or LO appears, consult Table 3-3 for an explanation of the error. If the error is a hardware failure, turn the instrument off and then on again. If the error condition persists, have the instrument serviced by a qualified service person.

Table 3-3: AM 503B and AM 5030 Front-Panel Error Codes

Error Number	Description of Error
263	Probe opened during degauss/autobalance.
266	The Amplifier OUTPUT was not terminated into 50 Ω . It can also be caused by faulty hardware.
267	Internal buffer overflow.
350-354	Amplifier needs repair.
355	NVRAM failure, Amplifier reset to factory default. Will occur first power up after new firmware has been installed.
356	Amplifier needs repair.
357 or LO	Internal battery is weak and needs replacement.
358	An error occurred while the Amplifier was restoring previously saved settings.
359	Probe needs repair; the Amplifier cannot recognize the probe type. Try removing and reconnecting the current probe, and make sure it is locked.
360-362	Amplifier needs repair.
363-364	Amplifier or probe needs repair.
550-594 750-768	Error occurred during internal automatic adjustment. Repeated errors in the range 550-594 indicate the Amplifier needs repair. 580 and 581 indicate that the Amplifier was unable to complete a probe offset adjustment. See the DC Offset Adjustment procedure for the particular probe you are using.

Troubleshooting

Table 3–4 lists possible problems that you may encounter when measuring current with the AM 503B and AM 5030. Use this as a quick troubleshooting reference.

Table 3–4: Troubleshooting

Problem	Remedy
Amplifier will not power up, though the TM Series Power Module does power up.	Move the Amplifier to another slot in the TM Series Power Module. (Power transistors in that position of the TM Series Power Module may be defective. This may be the case even if other TM 500 or TM 5000 instruments work in that position; not all instruments use the power module power transistors.)
Front panel displays error code 266 .	The Amplifier is not terminated into 50 Ω . Set oscilloscope input impedance to 50 Ω , and input coupling to DC. (If the oscilloscope input impedance is fixed at 1 M Ω , attach a 50 Ω termination (see replaceable parts list) at the oscilloscope input. Do not attach the termination at the Amplifier output.)
Front panel displays error code 357 or LO .	Battery is weak. Battery replacement should be performed by a qualified service person.
Front panel displays an error code.	Note the error code and turn the instrument off. Review installation and operating information in this manual. Power up the instrument. If the error condition persists, refer the instrument to qualified service personnel for repair.
Cannot make a current measurement.	Current Probe is not locked. Current Probe is improperly connected to the Amplifier input connector. Coupling is set to REF position. Change to AC or DC.
Cannot degauss the probe.	Current Probe is not locked. Current Probe is improperly connected to the Amplifier input connector.
Stray DC component in measurement.	Degauss the probe using the PROBE DEGAUSS AUTOBALANCE button. (The Current Probe has been overloaded, bumped, or exposed to magnetic field.)

Table 3–4: Troubleshooting (Cont.)

Problem	Remedy
Measurements are inaccurate.	<p>Degauss the probe.</p> <p>The Amplifier output is not terminated into 50 Ω load. Set the input impedance of oscilloscope to 50 Ω or connect a 50 Ω feedthrough termination at the oscilloscope input. Do not attach the termination at the Amplifier output.</p> <p>Set the vertical amplifier of the oscilloscope to 10 mV/div.</p> <p>Adjust the oscilloscope ground reference.</p> <p>Adjust the Amplifier OUTPUT DC LEVEL control to the zero-current reference.</p> <p>The measurement exceeds the maximum continuous current or Ampere-second product ratings of the Current Probe. If possible, upgrade to a probe with a higher current rating or use a CT-4 transformer.</p>
Measurements roll off at high frequencies.	<p>The Amplifier or oscilloscope bandwidth limit is turned on. Verify that bandwidth limit switches of <i>both</i> the Amplifier and the oscilloscope are set to the full bandwidth position.</p> <p>(Be careful not to exceed the frequency limit of the probe used. Frequencies above the probe design may cause overheating and damage to the probe.)</p>
Measurements exhibit excessive noise.	<p>Current Probe is not locked.</p> <p>Current Probe is improperly connected to the Amplifier input.</p> <p>Amplifier output is not terminated into 50 Ω load. Set input impedance of oscilloscope to 50 Ω or connect a 50 Ω feed-through termination at the oscilloscope input, <i>not</i> at the Amplifier output.</p>
Measurement aberrations exceed the specified limit.	<p>The Amplifier output is not terminated into 50 Ω load. Set the input impedance of oscilloscope to 50 Ω or connect a 50 Ω feedthrough termination (see the replaceable parts list) at the oscilloscope input. Do not attach the termination to Amplifier output.</p> <p>The measurement exceeds the maximum continuous current or Ampere-second product ratings of the Current Probe. (For more information, see <i>Current Limits</i> on page 3–4.) If possible, upgrade to a probe with a higher current rating or use a CT-4 transformer.</p>
Measurements exhibit excessive delay or slowed pulse response.	<p>The Amplifier output is not terminated into 50 Ω load. Set the input impedance of oscilloscope to 50 Ω or connect a 50 Ω feedthrough termination (see the replaceable parts list) at the oscilloscope input. Do not attach the termination to Amplifier output.</p> <p>The measurement exceeds the Ampere-second product of the Current Probe. If possible, upgrade to a probe with a higher current rating or use a CT-4 transformer.</p> <p>Bandwidth limit is turned on. Verify that bandwidth limit switches of <i>both</i> the Amplifier and the oscilloscope are set to the full bandwidth position.</p>



Specifications

Specifications

For additional probe specifications, refer to the probe's *Instructions*.

These specifications are valid only under the following conditions:

- The probe and amplifier have been calibrated at an ambient temperature between +20° C and +30° C.
- The probe and amplifier are operating in an environment whose limits are described in Table 4-4 (the operating temperature limits are 0° C to +50° C, unless otherwise stated).
- The probe and amplifier have had a warm-up period of at least 20 minutes.
- The probe degauss/autobalance routine has been performed after the 20-minute warm-up period, and thereafter whenever the PROBE DEGAUSS/AUTOBALANCE light blinks.
- The Amplifier output is properly terminated into 50 Ω .

Specifications are separated into two categories: warranted specifications and nominal or typical characteristics.

Because of a change in the probe input connector, the performance specifications are guaranteed only for probes having the following serial numbers:

A6302 B050000 and above
A6303 B022000 and above
A6302XL . . . All
A6303XL . . . All
A6304XL . . . All

Probes with earlier serial numbers can be updated; contact your nearest Tektronix Service Center.

Warranted Specifications

Warranted specifications, Table 4–1, are guaranteed performance specifications unless specifically designated as typical or nominal.

Table 4–1: Warranted AM 503B and AM 5030 Specifications

Parameter	Installed Probe				
	A6302	A6303	A6302XL	A6303XL	A6304XL
Bandwidth	DC to 50 MHz, –3 dB	DC to 15 MHz, –3 dB	DC to 17 MHz, –3 dB	DC to 10 MHz, –3 dB	DC to 2 MHz, –3 dB
Rise Time, 10% to 90%	≤ 7 ns	≤ 23 ns	≤ 20 ns	≤ 35 ns	≤ 175 ns
DC Gain Accuracy	±3% of (reading – [DC Balance + DC Level Accuracy])	±3% of (reading – [DC Balance + DC Level Accuracy])	±3% of (reading – [DC Balance + DC Level Accuracy])	±3% of (reading – [DC Balance + DC Level Accuracy])	±3% of (reading – [DC Balance + DC Level Accuracy])
Output DC Level Accuracy	±0.5 divisions	±0.5 divisions	±0.5 divisions	±0.5 divisions	±0.5 divisions

Nominal and Typical Characteristics

Nominal and typical characteristics, Tables 4–2 and 4–3, are not guaranteed. They are provided to characterize the configuration, performance, or operation of typical probe/amplifier combinations.

Table 4–2: Nominal and Typical AM 503B and AM 5030 Characteristics

Parameter	Installed Probe				
	A6302	A6303	A6302XL	A6303XL	A6304XL
Current/Division Ranges, nominal, Oscilloscope at 10 mV/div	1 mA/div to 5 A/div, 1–2–5 sequence	5 mA/div to 50 A/div, 1–2–5 sequence	1 mA/div to 5 A/div, 1–2–5 sequence	5 mA/div to 50 A/div, 1–2–5 sequence	500 mA/div to 200 A/div, 1–2–5 sequence
Input Coupling, nominal	AC, DC, and REF	AC, DC, and REF	AC, DC, and REF	AC, DC, and REF	AC, DC, and REF
AC Coupling Low-Frequency Bandwidth, typical	<7 Hz, –3 dB	<7 Hz, –3 dB	<7 Hz, –3 dB	<7 Hz, –3 dB	<7 Hz, –3 dB
Output DC Level Adjustment Range, typical	±10 divisions	±10 divisions	±10 divisions	±10 divisions	±10 divisions
Output Dynamic Range, typical (Including Output DC Level Setting)	±10 divisions, ±100 mV	±10 divisions, ±100 mV	±10 divisions, ±100 mV	±10 divisions, ±100 mV	±10 divisions, ±100 mV
Displayed Noise, typical	<400 μA_{RMS} + 0.1 div _{RMS} Limit measurement bandwidth to 100 MHz.	<2.5 mA _{RMS} + 0.1 div _{RMS} Limit measurement bandwidth to 100 MHz.	<400 μA_{RMS} + 0.1 div _{RMS} Limit measurement bandwidth to 100 MHz.	<2.5 mA _{RMS} + 0.1 div _{RMS} Limit measurement bandwidth to 100 MHz.	<0.25 A _{RMS} + 0.1 div _{RMS} Limit measurement bandwidth to 20 MHz.

Table 4–2: Nominal and Typical AM 503B and AM 5030 Characteristics (Cont.)

Parameter	Installed Probe				
	A6302	A6303	A6302XL	A6303XL	A6304XL
Bandwidth Limit, –3 dB, typical	20 MHz \pm 4 MHz	12 MHz \pm 3 MHz	14 MHz \pm 2 MHz	9 MHz \pm 2 MHz	2 MHz \pm 10 kHz
Signal Delay, typical, with provided 50 Ω cable	approximately 30 ns	approximately 55 ns	approximately 60 ns	approximately 105 ns	approximately 105 ns

Table 4–3: AM 503B and AM 5030 Mechanical Characteristics

Parameter, nominal	Characteristic
Length	298 mm (11.7 in)
Height	127 mm (5.0 in)
Width	67 mm (2.63 in)
Weight	2 kg (4.4 lb)

Environmental Characteristics

The environmental characteristics in Table 4–4 are warranted performance specifications. Unlike the warranted characteristics in Table 4–1, the environmental characteristics are type tested; therefore there are no performance verification procedures provided to test these characteristics.

Table 4–4: AM 503B and AM 5030 Environmental Characteristics

Parameter	Characteristic
Ambient Temperature	
Operating	0° C to +50° C
Nonoperating	–55° C to +75° C
Humidity	
Operating	50° C, to 95% R.H.
Nonoperating	60° C, to 95% R.H.
Altitude	
Operating	4,570 m (15,000 ft) maximum
Nonoperating	15,200 m (50,000 ft) maximum
Random Vibration	
Operating	0.31 g _{RMS} , 5 Hz to 500 Hz, 10 minutes each axis
Nonoperating	2.46 g _{RMS} , 5 Hz to 500 Hz, 10 minutes each axis
Shock	30 g, 11 ms duration, half-sine pulses
Bench Handling	30 g, 11 ms duration, half-sine pulses
Topple Test	30 g, 11 ms duration, half-sine pulses
Transit Test, Packaged Product	38.1 cm (15 in) free-fall drop height, 91 kg (200 lb) compressive load, 32 mm (0.125 in) displacement, 30 minute vibration test, 1.33 g _{RMS} , 1 hour each axis random vibration test
Electro-Magnetic Compliance	Meets FCC Part 15, Subpart B, Class A Meets VFG 243–1991, as amended by VFG 46, 1992
Electro-Static Discharge	Meets IEC 801–2

Warning

The following servicing instructions are for use only by qualified personnel. To avoid personal injury, do not perform any servicing other than that contained in the operating instructions unless you are qualified to do so. Refer to General Safety Summary and Service Safety Summary prior to performing any service.





Performance Verification

Performance Verification Setup

The Performance Verification tests allow you to demonstrate that the Current Probe Amplifier/Current Probe meet their specified levels of performance. Since the AM 503B and AM 5030 cannot operate without a current probe, different procedures are provided so that you can use the one that matches your current probe.

Test Procedure Conditions

These procedures are valid only under the following conditions:

- The system has been calibrated at an ambient temperature between +20° C and +30° C.
- The system is operating in an environment whose limits are described in Table 4-4 on page 4-4.
- The system, including probe, has had a warm-up period of at least 20 minutes.
- The probe degauss/autobalance routine has been performed after the 20-minute warm-up period.

Equipment Preparation

Before performing the verification tests, install all plug-in units into the power module and turn the power on. Verify that the AM 503B and AM 5030 front panel controls operate as described in the operation information section. Turn any remaining equipment on and allow the entire system, including the attached probe, to warm up for a minimum of 20 minutes.

NOTE. Before performing any verification procedure, properly degauss the probe. Remove the probe from any current-carrying conductor, lock the probe, and press the Amplifier **PROBE DEGAUSS AUTOBALANCE** button. The degauss/autobalance routine is complete when the indicator light turns off.

The Amplifier front panel will display an error code **266** during the degauss/autobalance routine if the Amplifier is not properly terminated into 50 Ω. Verify that the oscilloscope input is 50 Ω and set to DC coupling. Use a 50 Ω feedthrough termination, attached at the oscilloscope input, if necessary.

Performance Verification with an A6302 or A6302XL

The test procedures in this section verify proper performance of the AM 503B and AM 5030 Amplifiers with an A6302 or A6302XL current probe. Tolerances that are specified in these procedures apply to the Amplifier and current probe and do not include test equipment error.

No probe or Amplifier adjustments are required during these test procedures. Should any test fail, refer to the troubleshooting section for troubleshooting recommendations.

Read page 5-1 before starting these procedures. Also, read each procedure through completely before starting to ensure proper completion.

Required Test Equipment

To perform the acceptance tests in this section, you will need the test equipment listed in Table 5-1. The test equipment must meet or exceed the specifications listed. The test procedures may need to be modified if the recommended equipment is not used.

Table 5-1: Required Test Equipment

Qty	Item	Description	Recommended Equipment
1	Oscilloscope	350 MHz bandwidth	TDS 460
1	Leveled Sine Wave Generator	3 MHz to >50 MHz	SG 503
1	Digital Multimeter	0.75% 3 ¹ / ₂ digit resolution	DMM254
1	Calibration Generator	1 MHz square wave, rise time <1 ns, 5 V _{p-p} into 50 Ω	PG 506A
1	Power Supply with output meter	0-5 Amp 0.75% meter accuracy	PS282
1	Calibration Fixture	50 Ω, BNC Connector	015-0601-50
1	Current Loop	100 turns 31 AWG coated wire (0.27 mm diameter with coating)	Refer to page 5-8.
1	Termination ¹	50 Ω, ±2%, 0.5 W	011-0049-01
3	BNC Cables ¹	50 Ω, 1.05 m (42 in) long	012-0057-01
1	BNC to Dual Banana Adapter		103-0090-00

¹ One provided as a standard accessory with the AM 503B and AM 5030.

Bandwidth

This procedure tests the bandwidth of the AM 503B and AM 5030. In this test you measure a signal at a relatively low frequency and again at the rated bandwidth of the system. The two measurements are compared to verify that the signal amplitude does not fall below -3 dB at the system bandwidth. Refer to Figure 5–1 when making equipment connections.

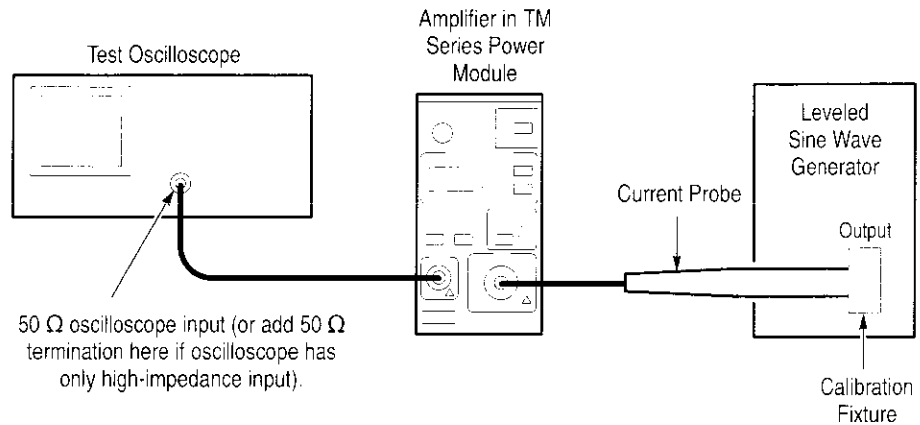

Figure 5–1: Bandwidth Test Setup for A6302

Equipment Connections

1. Using a $50\ \Omega$ BNC cable, connect the Amplifier **OUTPUT** to a $50\ \Omega$ oscilloscope input. If the input impedance of your oscilloscope is $1\ \text{M}\Omega$, connect a $50\ \Omega$ feedthrough termination at the oscilloscope input. Do not connect the termination at the Amplifier output.
2. Connect the current probe to the Amplifier **INPUT**.
3. Connect the current loop calibration fixture to the output of the leveled sine wave generator (SG 503).

Equipment Settings

Make or verify the equipment settings in Table 5–2:

Table 5–2: Equipment Settings for Bandwidth

Oscilloscope	
Vertical input impedance	$50\ \Omega$
Vertical gain	10 mV/division
Time base	250 ns/division
Record length	500
Coupling	DC
Offset	0 V (mid-scale)

Table 5–2: Equipment Settings for Bandwidth (Cont.)

Oscilloscope	
Trigger type	Edge
Trigger mode	Auto
Trigger position	50%
Acquisition mode	Average
Number of waveforms to average	8
Measurement type	Peak-to-Peak
Leveled Sine Wave Generator	
Frequency	3 MHz
Amplitude	3 V _{p-p}
AM 503B and AM 5030	
Coupling	DC
BW Limit	Off (full bandwidth)
Current/division	10 mA/division

Procedure

1. Do not clamp the current probe around any conductor, but make sure the jaws are locked shut.
2. Press the Amplifier **PROBE DEGAUSS AUTOBALANCE** button. Wait for the degauss/autobalance routine to complete before proceeding. The routine is complete when the indicator light turns off.
3. Clamp the current probe around the calibration fixture.
4. Adjust the signal generator output so that the Amplifier output is approximately 60 mV_{p-p}, or six graticule divisions on the oscilloscope.
5. Using the peak-peak measurement capability of the oscilloscope, measure and record the peak-peak reading as M_1 .
6. Set the oscilloscope time base to 10 ns/division. Increase the signal generator frequency to the warranted bandwidth. Refer to Table 4–1 on page 4–2.
7. Using the peak-peak measurement capability of the oscilloscope, measure and record the peak-peak reading as M_2 .
8. The system meets the bandwidth specification if the ratio of the signal amplitude at the warranted bandwidth is at least 70.7% of the signal amplitude at 3 MHz. Using the following calculation, verify system bandwidth:

$$\left(\frac{M_2}{M_1}\right) > 0.707$$

NOTE. The impedance of the calibration fixture used in this test changes slightly between 3 MHz and 50 MHz. Typically the impedance changes from 50 Ω at 3 MHz to 53 Ω at 50 MHz. Thus you can substitute the following equation to make this test more accurate:

$$(1.06) \left(\frac{M_2}{M_1} \right) > 0.707$$

Rise Time

This procedure measures the rise time of the AM 503B and AM 5030. In this test you directly measure the rise time of a step input. Refer to Figure 5–2 when making equipment connections.

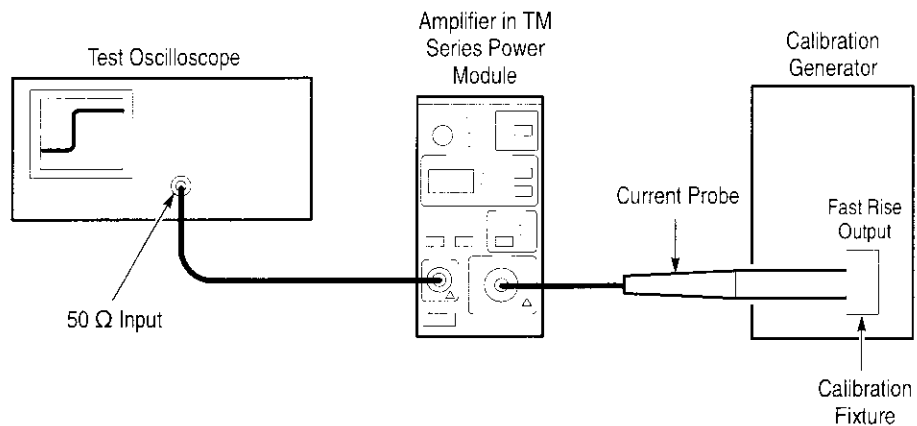

Figure 5–2: Rise Time Test Setup for A6302/A6302XL

Equipment Connections

1. Using a 50 Ω BNC cable, connect the Amplifier **OUTPUT** to a 50 Ω oscilloscope input. If the input impedance of your oscilloscope is 1 MΩ, connect a 50 Ω feedthrough termination at the oscilloscope input. Do not connect the termination at the Amplifier output.
2. Connect the current probe to the Amplifier **INPUT**.
3. Connect the current loop calibration fixture to the calibration generator 50 Ω fast rise output.

NOTE. If your oscilloscope cannot trigger on the pulse, use another BNC cable to connect the trigger output of the pulse generator to the trigger input of the oscilloscope. Configure the oscilloscope for an external trigger.

Equipment Settings

Make or verify the equipment settings in Table 5–3:

Table 5–3: Equipment Settings for Rise Time

Oscilloscope	
Vertical input impedance	50 Ω
Vertical gain	10 mV/division
Time base	2 ns/division
Record length	500
Coupling	DC
Offset	0 V (mid-scale)
Trigger type	Edge
Trigger mode	Auto
Trigger position	50%
Acquisition mode	Average
Number of waveforms to average	8
Measurement type	Rise Time
Calibration Generator	
Period	1 μ s
Output	Fast rise
Amplitude	Maximum
AM 503B and AM 5030	
Coupling	DC
BW Limit	Off (full bandwidth)
Current/division	5 mA/division

Procedure

1. Do not clamp the current probe around any conductor, but make sure the jaws are locked shut.
2. Press the Amplifier **PROBE DEGAUSS AUTOBALANCE** button. Wait for the degauss/autobalance routine to complete before proceeding. The routine is complete when the indicator light turns off.
3. Clamp the current probe around the calibration fixture. Verify that the arrow-shaped indicator on the probe points away from the pulse source.
4. Using the measurement capability of the oscilloscope, measure the rise time of the displayed pulse from 10% to 90% amplitude.

5. Verify that the rise time is less than the warranted specification. Refer to Table 4-1 on page 4-2.

DC Accuracy

This procedure tests the DC accuracy of the AM 503B and AM 5030. In this test you compare the voltage output of the Amplifier to a reference input. A multiple-turn current loop is used to keep the measured test current equivalent to a five-division signal for each current/division setting of the Amplifier. Figures 5-3 and 5-4 show how the current loop is connected to the test equipment in the DC accuracy test setup.

Current Loop for DC Accuracy Check

You will need to construct a simple current loop in order to complete the DC accuracy tests. Construct the loop as follows:



CAUTION. *It is not recommended that a coil with greater than 100 turns be made. Magnetic fields are produced that may cause a malfunction in heart pacemakers, or damage to sensitive equipment. Coil currents in excess of 250 mA are not recommended.*

1. Using a cylindrical form approximately 3 inches in diameter, wind *exactly* 100 turns of #31 coated wire.

NOTE. *Ensure that the current loop has exactly 100 turns. A significant error will result for each turn variance from 100 turns.*

Equipment Connections

1. Using a BNC cable, connect the Amplifier **OUTPUT** to the 50 Ω feed-through termination. Attach the termination to a BNC-to-dual banana adapter. Taking care to observe and maintain polarity, insert the dual banana adapter into the digital multimeter DC voltage input.
2. Connect the current loop and resistor to the voltage/current source as shown in Figure 5-3.

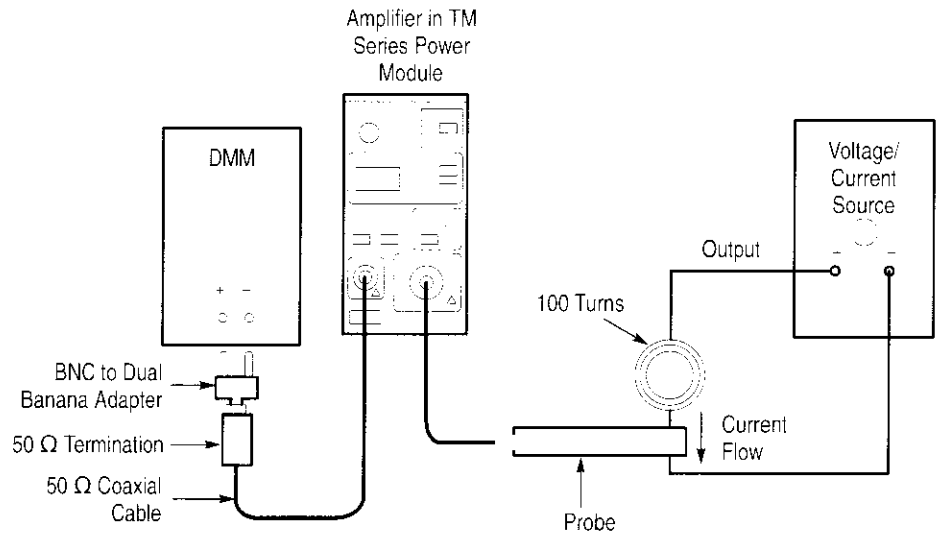

Figure 5-3: DC Accuracy Test Setup for A6302/A6302XL: 1 mA to 50 mA

Equipment Settings

Make or verify the equipment settings in Table 5-4:

Table 5-4: Equipment Settings for DC Accuracy

Digital Multimeter	
Measurement Type	DC volts
Range	Autoranging
Voltage/Current Source	
Output	Off
Readout	Amps
Amps	Low
Current Limit	Minimum
Voltage Limit	10.0 V
AM 503B and AM 5030	
Coupling	DC
BW Limit	On (20 MHz)
Current/division	1 mA/division

Procedure

1. Do not clamp the current probe around any conductor, but make sure the jaws are locked shut.
2. Press the Amplifier **PROBE DEGAUSS AUTOBALANCE** button. Wait for the degauss/autobalance routine to complete before proceeding. The routine is complete when the indicator light turns off.

3. Clamp the current probe around the one conductor of the current loop, as shown in Figure 5-3 on page 5-9. Verify that the arrow-shaped indicator on the probe points away from the current source.
4. For each of the Amplifier current/division settings in Table 5-5 on page 5-10, perform the following steps:
 - a. Verify that the voltage/current source output is off.
 - b. Adjust the Amplifier **DC LEVEL** control counterclockwise to obtain a digital multimeter reading of approximately -25 mV ($\pm 5\text{ mV}$). Record the exact measurement as M_1 . (You can copy Table 5-7 on page 5-13 to record the results of your measurements.)
 - c. Turn on the voltage/current source and adjust the output to the current specified in Table 5-5.

Table 5-5: DC Accuracy Test for A6302/A6302XL: 1 mA to 50 mA

Turns of Current Loop Passing Through Probe	AM 503B and AM 5030 Current/Division	Voltage/Current Source Output	Test Current I_t
1	1 mA	5 mA	5 mA
1	2 mA	10 mA	10 mA
1	5 mA	25 mA	25 mA
1	10 mA	50 mA	50 mA
1	20 mA	100 mA	100 mA
1	50 mA	250 mA	250 mA

- d. Record the digital multimeter reading as M_2 .
- e. Calculate the measured current (I_m) using the following formula:

$$I_m = \frac{M_2 - M_1}{0.01} \times (\text{current/division})$$

For example, you might have obtained values of -24.6 mA for M_1 and 25 mA for M_2 . If you are using an Amplifier setting of 10 mA/division , you can compute I_m as:

$$I_m = \frac{(25.0 \times 10^{-3}) - (-24.6 \times 10^{-3})}{0.01} \times (10 \times 10^{-3}) = 49.6\text{ mA}$$

- f. Verify that the measured current (I_m) is within $\pm 3\%$ of the test current (I_t) by computing $\%Error$ as follows:

$$\%Error = \frac{I_m - I_t}{I_t} \times 100$$

For example, using a test current I_t of 50 mA and a measured current I_m of 49.6 mA, the $\%Error$ would be:

$$\%Error = \frac{49.6 - 50.0}{50.0} \times 100 = -0.8\%$$

5. Clamp the current probe around the 100 turn current loop. Refer to Figure 5-4. Verify that the arrow-shaped indicator on the probe points away from the current source.

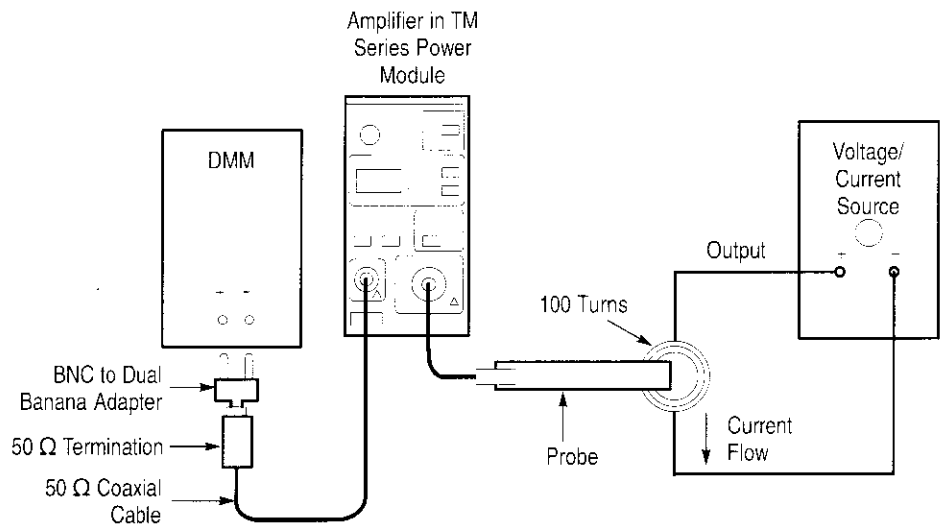

Figure 5-4: DC Accuracy Test Setup for A6302/A6302XL: 100 mA to 5 A

6. For each of the Amplifier current/division settings in Table 5-6 on page 5-12, perform the following steps:
 - a. Verify that the voltage/current source output is off.
 - b. Adjust the Amplifier **DC LEVEL** control counterclockwise to obtain a digital multimeter reading of approximately -25 mV (± 5 mV). Record the exact measurement as M_I . (You can copy Table 5-7 on page 5-13 to record the results of your measurements.)
 - c. Turn on the voltage/current source and adjust the output to obtain current specified in Table 5-6.

Table 5-6: DC Accuracy Test for A6302/A6302XL: 100 mA to 5 A

Turns of Current Loop Passing Through Probe	AM 503B and AM 5030 Current/Division	Voltage/Current Source Output	Test Current I_t
100	100 mA	5 mA	500 mA
100	200 mA	10 mA	1 A
100	500 mA	25 mA	2.5 A
100	1 A	50 mA	5 A
100	2 A	100 mA	10 A
100	5 A	200 mA	20 A

- d. Record the digital multimeter reading as M_2 .
- e. Calculate the measured current (I_m) using the following formula:

$$I_m = \frac{M_2 - M_1}{0.01} \times (\text{current/division})$$

For example, you might have obtained values of -24.6 mA for M_1 and 25.0 mA for M_2 . If you are using an Amplifier setting of 100 mA/division, you can compute I_m as:

$$I_m = \frac{(25.0 \times 10^{-3}) - (-24.6 \times 10^{-3})}{0.01} \times (100 \times 10^{-3}) = 496 \text{ mA}$$

- f. Verify that the measured current (I_m) is within $\pm 3\%$ of the test current (I_t) by computing $\%Error$ as follows:

$$\%Error = \frac{I_m - I_t}{I_t} \times 100$$

For example, using a test current I_t of 500 mA and a measured current I_m of 496 mA, the $\%Error$ would be:

$$\%Error = \frac{496 - 500}{500} \times 100 = -0.8\%$$

Table 5-7: DC Accuracy Test Worksheet for A6302/A6302XL

Turns of Current Loop Passing Through Probe	AM 503B and AM 5030 Current/Division	Current/Voltage Source Output	Test Current I_t	M_1	M_2	I_m (Note A)	%Error (Note B)
1	1 mA	5 mA	5 mA				
1	2 mA	10 mA	10 mA				
1	5 mA	25 mA	25 mA				
1	10 mA	50 mA	50 mA				
1	20 mA	100 mA	100 mA				
1	50 mA	250 mA	250 mA				
100	100 mA	5 mA	500 mA				
100	200 mA	10 mA	1 A				
100	500 mA	25 mA	2.5 A				
100	1 A	50 mA	5 A				
100	2 A	100 mA	10 A				
100	5 A	200 mA	20 A				

Note A

$$I_m = \frac{M_2 - M_1}{0.01} \times (\text{current/division})$$

Note B

$$\%Error = \frac{I_m - I_t}{I_t} \times 100$$

Performance Verification with an A6303 or A6303XL

The test procedures in this section check for proper performance of the AM 503B and AM 5030 with an A6303 or A6303XL current probe. Tolerances that are specified in these procedures apply to the Amplifier and current probe and do not include test equipment error.

No probe or Amplifier adjustments are required during these test procedures. Should any tests fail, refer to the troubleshooting section for troubleshooting recommendations.

Read page 5-1 before starting these procedures. Also, read each procedure through completely before starting to ensure proper completion.

Required Test Equipment

To perform the acceptance tests in this section, you will need the test equipment listed in Table 5-8. The test equipment must meet or exceed the specifications listed. The test procedures may need to be modified if the recommended equipment is not used.

Table 5-8: Required Test Equipment

Qty	Item	Description	Recommended Equipment
1	Oscilloscope	350 MHz bandwidth	TDS 460
1	Leveled Sine Wave Generator	3 MHz to >50 MHz	SG 503
1	Calibration Generator	1 MHz square wave, rise time <1 ns, 5 V _{p-p} into 50 Ω	PG 506A
1	Digital Multimeter	0.75% 3 ¹ / ₂ digit resolution	DMM254
1	Power Supply with output meter	0-5 Amp 0.75% meter accuracy	PS282
1	Calibration Fixture	50 Ω, BNC Connector	015-0601-50
1	Current Loop	250 turns	067-0240-00
1	Termination ¹	50 Ω, ±2%, 0.5 W	011-0049-01
3	BNC Cables ¹	50 Ω, 1.05 m (42 in) long	012-0057-01
1	BNC to Dual Banana Adapter		103-0090-00

¹ One provided as a standard accessory with the AM 503B and AM 5030.

Bandwidth

This procedure tests the bandwidth of the AM 503B and AM 5030. In this test you measure a signal at a relatively low frequency and again at the rated bandwidth of the system. The two measurements are compared to check that the signal amplitude does not fall below -3 dB at the system bandwidth. Refer to Figure 5-5 when making equipment connections.

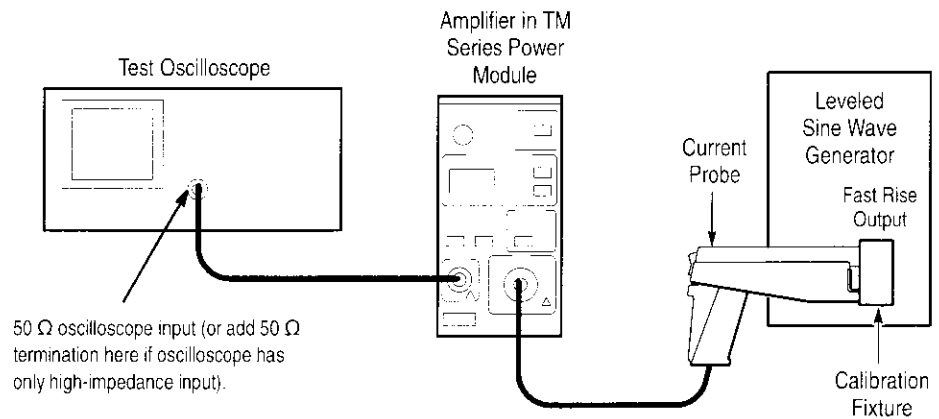

Figure 5-5: Bandwidth Test Setup for an A6303 or A6303XL

Equipment Connections

1. Using a 50 Ω BNC cable, connect the Amplifier **OUTPUT** to a 50 Ω oscilloscope input. If the input impedance of your oscilloscope is 1 M Ω , connect a 50 Ω feedthrough termination at the oscilloscope input. Do not connect the termination at the Amplifier output.
2. Connect the current probe to the Amplifier **INPUT**.
3. Connect the current loop calibration fixture to the output of the leveled sine wave generator.

Equipment Settings

Make or check the equipment settings in Table 5-9:

Table 5-9: Equipment Settings for Bandwidth

Oscilloscope	
Vertical input impedance	50 Ω
Vertical gain	10 mV/division
Time base	200 ns/division
Record length	500
Coupling	DC
Offset	0 V (mid-scale)
Trigger type	Edge

Table 5–9: Equipment Settings for Bandwidth (Cont.)

Oscilloscope	
Trigger mode	Auto
Trigger position	50%
Acquisition mode	Average
Number of waveforms to average	8
Measurement type	Peak-to-Peak
Leveled Sine Wave Generator	
Frequency	3 MHz
Amplitude	3 V _{p-p}
AM 503B and AM 5030	
Coupling	DC
BW Limit	Off
Current/division	10 mA/division

- Procedure**
1. Do not clamp the current probe around any conductor, but make sure the jaws are locked shut.
 2. Press the Amplifier **PROBE DEGAUSS AUTOBALANCE** button. Wait for the degauss/autobalance routine to complete before proceeding. The routine is complete when the indicator light turns off.
 3. Clamp the current probe around the current loop calibration fixture.
 4. Adjust the signal generator output so that the Amplifier output is $\approx 60 \text{ mV}_{p-p}$, or six graticule divisions on the oscilloscope.
 5. Using the peak-peak measurement capability of the oscilloscope, measure and record the peak-peak reading as M_1 .
 6. Set the oscilloscope time base to 50 ns/division. Increase the signal generator frequency to the warranted bandwidth. Refer to Table 4–1 on page 4–2.
 7. Using the peak-peak measurement capability of the oscilloscope, measure and record the peak-peak reading as M_2 .
 8. The system meets the bandwidth specification if the ratio of the signal amplitude at the warranted bandwidth is at least 0.707 of the signal amplitude at 3 MHz. Using the following calculation, check system bandwidth:

$$\left(\frac{M_2}{M_1}\right) > 0.707$$

Rise Time

This procedure measures the rise time of the AM 503B and AM 5030. In this test you directly measure the rise time of a step input. Refer to Figure 5–6 when making equipment connections.

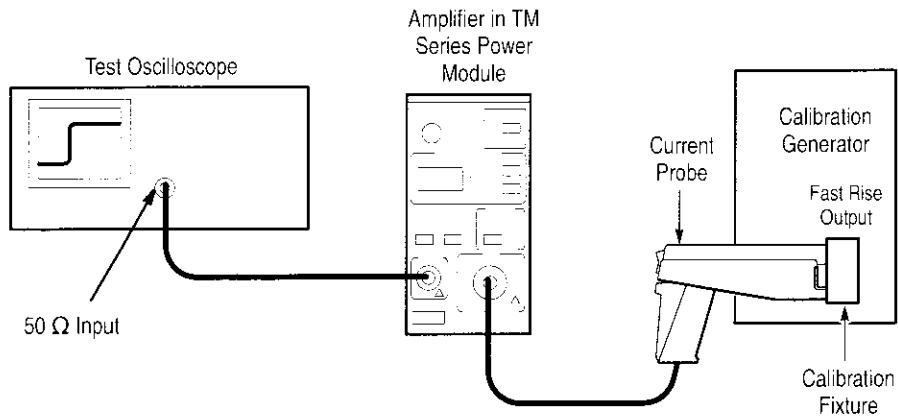

Figure 5–6: Rise Time Test Setup for A6303 or A6303XL

Equipment Connections

1. Using a BNC cable, connect the Amplifier **OUTPUT** to a 50 Ω oscilloscope input. If the input impedance of your oscilloscope is 1 MΩ, connect a 50 Ω feedthrough termination at the oscilloscope input. Do not connect the termination at the Amplifier output.
2. Connect the probe to the Amplifier.
3. Connect the current loop calibration fixture to the calibration generator 50 Ω fast rise output.

NOTE. *If your oscilloscope cannot trigger on the pulse, use another BNC cable to connect the trigger output of the pulse generator to the trigger input of the oscilloscope. Configure the oscilloscope for an external trigger.*

Equipment Settings

Make or check the equipment settings in Table 5–10:

Table 5–10: Equipment Settings for Rise Time

Oscilloscope	
Vertical input impedance	50 Ω
Vertical gain	5 mV/division
Time base	10 ns/division
Record length	500
Coupling	DC
Offset	0 V (mid-scale)
Trigger type	Edge
Trigger mode	Auto
Trigger position	50%
Acquisition mode	Average
Number of waveforms to average	8
Measurement type	Rise Time
Calibration Generator	
Period	1 μ s
Output	Fast Rise
Amplitude	Maximum
AM 503B and AM 5030	
Coupling	DC
BW Limit	Off
Current/division	5 mA/division

NOTE. This is the only test where the oscilloscope vertical gain should be set at other than 10 mV/division. Reset the vertical gain to 10 mV/division when the rise time check is complete.

- Procedure**
1. Do not clamp the current probe around any conductor, but make sure the jaws are locked shut.
 2. Press the Amplifier **PROBE DEGAUSS AUTOBALANCE** button. Wait for the degauss/autobalance routine to complete before proceeding. The routine is complete when the indicator light turns off.
 3. Clamp the current probe around the current loop calibration fixture. Check that the arrow-shaped indicator on the probe points away from the source.
 4. Using the measurement capability of the oscilloscope, measure the rise time of the displayed pulse from 10% to 90% amplitude.
 5. Check that the rise time is less than the warranted specification. Refer to Table 4–1 on page 4–2.
 6. Reset the oscilloscope vertical gain to 10 mV/division.

DC Accuracy



WARNING. *This test produces intense magnetic fields that may cause malfunctions in a normally operating heart pacemaker or damage sensitive equipment. Personnel fitted with pacemakers should not perform this test, and should stay at least 10 feet from the current loop while the test is being conducted.*

This procedure tests the DC accuracy of the AM 503B and AM 5030. In this test you compare the voltage output of the Amplifier to a reference input. A multiple-turn current loop is used to keep the measured test current equivalent to a five-division signal for each current/division setting of the Amplifier. Figures 5-7 and 5-8 show how the current loop is connected to the test equipment in the DC accuracy test setup.

Equipment Settings

Make or check the equipment settings in Table 5-11:

Table 5-11: Equipment Settings for DC Accuracy

Digital Multimeter	
Measurement Type	DC volts
Range	Autoranging
Voltage/Current Source	
Output	Off
Readout	Amps
Amps	Low
Current Limit	Minimum
Voltage Limit	2.0 V
AM 503B and AM 5030	
Coupling	DC
BW Limit	On
Current/division	5 mA/division

Equipment Connections

1. Using a BNC cable, connect the Amplifier **OUTPUT** to a 50 Ω feedthrough termination. Attach the termination to a BNC-to-dual banana adapter. Taking care to observe the adapter polarity, insert the dual banana adapter into the digital multimeter DC voltage input.
2. Connect the current loop to the voltage/current source as shown in Figure 5-7.

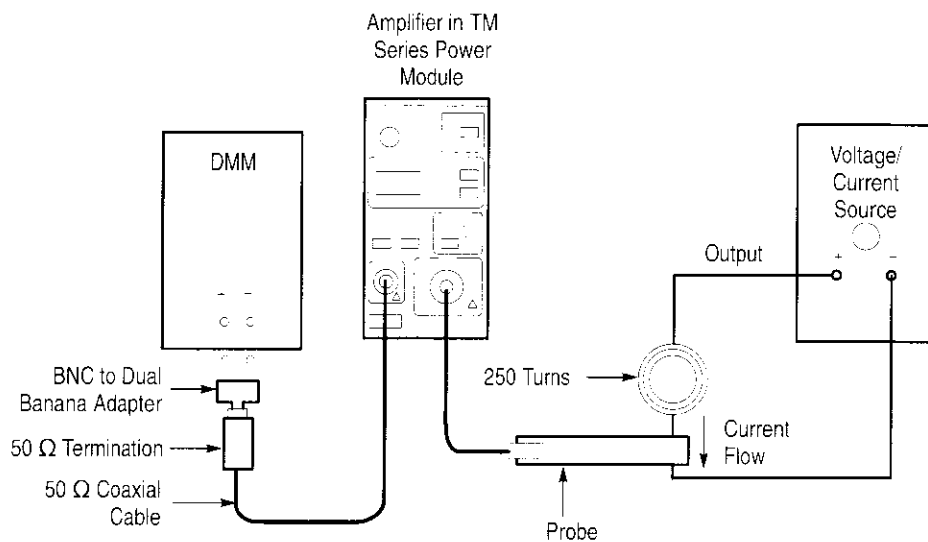

Figure 5-7: DC Accuracy Test Setup for A6303/A6303XL: 5 mA to 200 mA



WARNING. This test produces intense magnetic fields that may cause malfunctions in a normally operating heart pacemaker or damage sensitive equipment. Personnel fitted with pacemakers should not perform this test, and should stay at least 10 feet from the current loop while the test is being conducted.

Procedure

1. Do not clamp the current probe around any conductor, but make sure the jaws are locked shut.
2. Press the Amplifier **PROBE DEGAUSS AUTOBALANCE** button. Wait for the degauss/autobalance routine to complete before proceeding. The routine is complete when the indicator light turns off.
3. Clamp the current probe around the one conductor of the current loop. (See Figure 5-7 on page 5-21.) Check that the arrow-shaped indicator on the probe points away from the current source.
4. For each of the Amplifier current/division settings in Table 5-12 on page 5-22, perform the following steps:
 - a. Check that the voltage/current source output is off.
 - b. Adjust the Amplifier **DC LEVEL** control counterclockwise to obtain a digital multimeter reading of approximately -25 mV ($\pm 5\text{ mV}$). Record the exact measurement as M_I . (You can copy Table 5-14 on page 5-25 to record the results of your measurements.)
 - c. Turn on the voltage/current source and adjust the output to obtain the current specified in Table 5-12.

Table 5-12: DC Accuracy Test for A6303/A6303XL: 5 mA to 200 mA

Turns of Current Loop Passing Through Probe	AM 503B and AM 5030 Current/Division	Voltage/Current Source Output	Test Current I_t
1	5 mA	2.5 V	25 mA
1	10 mA	5.0 V	50 mA
1	20 mA	10.0 V	100 mA
1	50 mA	250 mA	250 mA
1	100 mA	500 mA	500 mA
1	200 mA	1 A	1 A

- d. Record the digital multimeter reading as M_2 .
- e. Calculate the measured current (I_m) using the following formula:

$$I_m = \frac{M_2 - M_1}{0.01} \times (\text{current/division})$$

For example, you might have obtained values of -24.6 mA for M_1 and 25 mA for M_2 . If you are using an Amplifier setting of 10 mA/division, you can compute I_m as:

$$I_m = \frac{(25.0 \times 10^{-3}) - (-24.6 \times 10^{-3})}{0.01} \times (10 \times 10^{-3}) = 49.6 \text{ mA}$$

- f. Check that the measured current (I_m) is within $\pm 3\%$ of the test current (I_t) by computing $\%Error$ as follows:

$$\%Error = \frac{I_m - I_t}{I_t} \times 100$$

For example, using a test current I_t of 50 mA and a measured current I_m of 49.6 mA, the $\%Error$ would be:

$$\%Error = \frac{49.6 - 50.0}{50.0} \times 100 = -0.8\%$$

5. Clamp the current probe around the 250 turn current loop. Check that the arrow-shaped indicator on the probe points away from the current source. Refer to Figure 5-8.

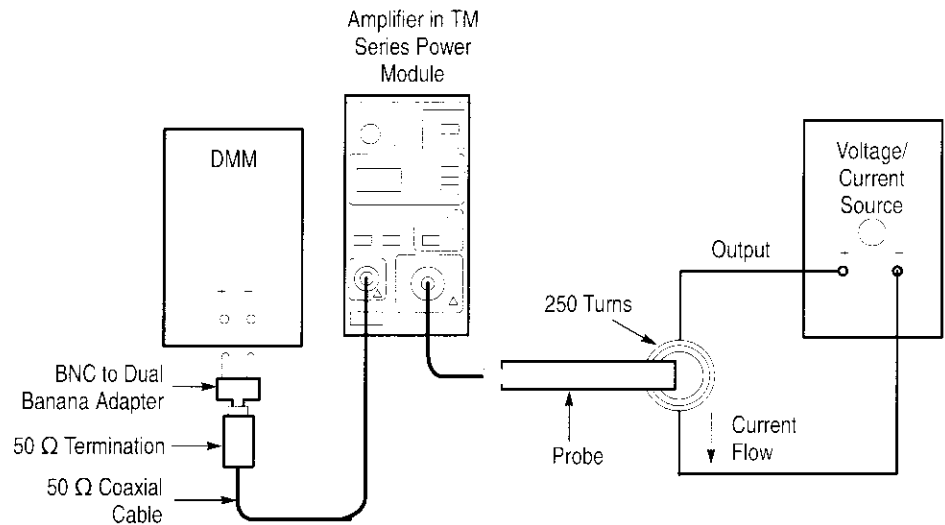

Figure 5–8: DC Accuracy Test Setup for A6303/A6303XL: 500 mA to 50 A

6. For each of the Amplifier current/division settings in Table 5–13 on page 5–23, perform the following steps:
 - a. Check that the voltage/current source output is off.
 - b. Adjust the Amplifier **DC LEVEL** control counterclockwise to obtain a digital multimeter reading of approximately -25 mV ($\pm 5\text{ mV}$). Record the exact measurement as M_1 . (You can copy Table 5–14 on page 5–25 to record the results of your measurements.)
 - c. Turn on the voltage/current source and adjust the output to obtain the current specified in Table 5–13.

Table 5–13: DC Accuracy Test for A6303/A6303XL: 500 mA to 50 A

Turns of Current Loop Passing Through Probe	AM 503B and AM 5030 Current/Division	Current/Voltage Source Output	Test Current I_t
250	500 mA	10 mA	2.5 A
250	1 A	20 mA	5 A
250	2 A	40 mA	10 A
250	5 A	100 mA	25 A
250	10 A	200 mA	50 A
250	20 A	400 mA	100 A
250	50 A	400 mA	100 A

- d. Record the digital multimeter reading as M_2 .
- e. Calculate the measured current (I_m) using the following formula:

$$I_m = \frac{M_2 - M_1}{0.01} \times (\text{current/division})$$

For example, you might have obtained values of -24.6 mA for M_1 and 25.0 mA for M_2 . If you are using an Amplifier setting of 10 A/division, you can compute I_m as:

$$I_m = \frac{(25.0 \times 10^{-3}) - (-24.6 \times 10^{-3})}{0.01} \times (10) = 49.6 \text{ A}$$

- f. Check that the measured current (I_m) is within $\pm 3\%$ of the test current (I_t) by computing $\%Error$ as follows:

$$\%Error = \frac{I_m - I_t}{I_t} \times 100$$

For example, using a test current I_t of 50 A and a measured current I_m of 49.6 A, the $\%Error$ would be:

$$\%Error = \frac{49.6 - 50.0}{50.0} \times 100 = -0.8\%$$

Table 5–14: DC Accuracy Test Worksheet for A6303/A6303XL

Turns of Current Loop Passing Through Probe	AM 503B and AM 5030 Current/Division	Voltage/Current Source Output	Test Current I_t	M_1	M_2	I_m (Note A)	%Error (Note B)
1	5 mA	25 mA	25 mA				
1	10 mA	50 mA	50 mA				
1	20 mA	100 mA	100 mA				
1	50 mA	250 mA	250 mA				
1	100 mA	500 mA	500 mA				
1	200 mA	1 A	1 A				
250	500 mA	10 mA	2.5 A				
250	1 A	20 mA	5 A				
250	2 A	40 mA	10 A				
250	5 A	100 mA	25 A				
250	10 A	200 mA	50 A				
250	20 A	400 mA	100 A				
250	50 A	400 mA	100 A				

Note A

$$I_m = \frac{M_2 - M_1}{0.01} \times (\text{current/division})$$

Note B

$$\%Error = \frac{I_m - I_t}{I_t} \times 100$$

Performance Verification with an A6304XL

The test procedures in this section check for proper performance of the AM 503B and AM 5030 with an current probe. Tolerances that are specified in these procedures apply to the Amplifier and current probe and do not include test equipment error. Table 5–15 is a list of equipment required for these procedures.

No probe or Amplifier adjustments are required during these test procedures. Should any tests fail, refer to the troubleshooting section for troubleshooting recommendations.

Read page 5–1 before starting these procedures. Also, read each procedure through completely before starting to ensure proper completion.

Required Test Equipment

To perform the acceptance tests in this section, you will need the test equipment listed in Table 5–15. The test equipment must meet or exceed the specifications listed. The test procedures may need to be modified if the recommended equipment is not used.

Table 5–15: Required Test Equipment

Qty	Item	Description	Recommended Equipment
1	Oscilloscope	20 MHz bandwidth	Tektronix TDS 460
1	Digital Multimeter	0.75% 3 ¹ / ₂ digit resolution	Tektronix DMM254
1	Calibration Generator	Square wave with a rise time <35 ns, 5 A into 50 Ω	AVTECH ¹ AVR-3-PW-C-P-TEK2
1	Power Supply with output meter	0–5 Amp 0.75% meter accuracy	Tektronix PS282
1	Current Loop	250 turns	067-0240-00
1	Termination ²	50 Ω, ±2%, 0.5 W	011-0049-01
3	BNC Cables ²	50 Ω, 1.05 m (42 in) long	012-0057-01
1	BNC to Dual Banana Adapter		103-0090-00

¹ AVTECH Electrosystems Ltd.
P.O. Box 265, Ogdensburg NY 13669-0265
(315) 472-5270 or (800) 265-6681

² One provided as a standard accessory with the AM 503B and AM 5030.

Rise Time

This procedure measures the rise time of the AM 503B and AM 5030. In this test you directly measure the rise time of a step input. Refer to Figure 5–9 when making equipment connections.

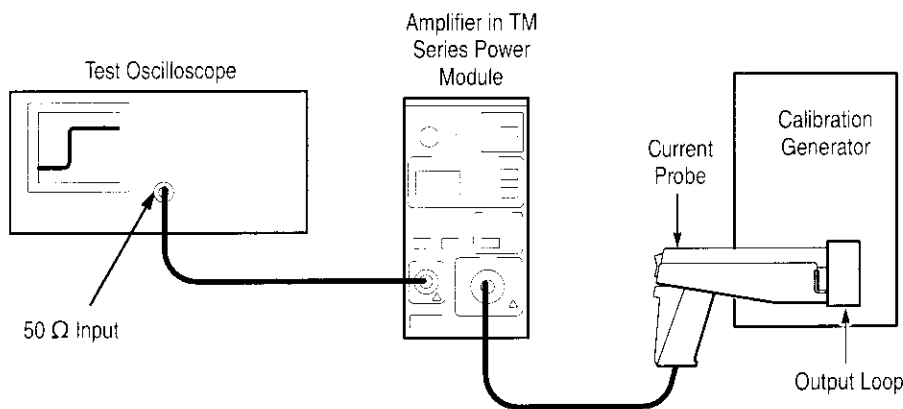

Figure 5–9: Rise Time Test Setup for the A6304XL

Equipment Connections

1. Using a BNC cable, connect the Amplifier **OUTPUT** to a 50 Ω oscilloscope input. If the input impedance of your oscilloscope is 1 MΩ, connect a 50 Ω feedthrough termination at the oscilloscope input. Do not connect the termination at the Amplifier output.
2. Connect the probe to the Amplifier.
3. Connect the current loop calibration fixture to the calibration generator 50 Ω fast rise output.

NOTE. If your oscilloscope cannot trigger on the pulse, use another BNC cable to connect the trigger output of the pulse generator to the trigger input of the oscilloscope. Configure the oscilloscope for an external trigger.

Equipment Settings Make or check the equipment settings in Table 5–16:

Table 5–16: Equipment Settings for Rise Time

Oscilloscope	
Vertical input impedance	50 Ω
Vertical gain	10 mV/division
Time base	50 ns/division
Record length	500
Coupling	DC
Offset	0 V (mid-scale)
Trigger type	Edge
Trigger mode	Auto
Trigger position	50%
Acquisition mode	Average
Number of waveforms to average	8
Measurement type	Rise Time
Calibration Generator	
Pulse width	250 μ s
Pulse repetition frequency	25 Hz
Amplitude	5 A peak
AM 503B and AM 5030	
Coupling	DC
BW Limit	Off
Current/division	1 A/division

- Procedure**
1. Do not clamp the current probe around any conductor, but make sure the jaws are locked shut.
 2. Press the Amplifier **PROBE DEGAUSS AUTOBALANCE** button. Wait for the degauss/autobalance routine to complete before proceeding. The routine is complete when the indicator light turns off.
 3. Clamp the current probe around the current loop calibration fixture. Check that the arrow-shaped indicator on the probe points away from the source.
 4. Using the measurement capability of the oscilloscope, measure the rise time of the displayed pulse from 10% to 90% amplitude.
 5. Check that the rise time is less than the warranted specification. Refer to Table 4–1 on page 4–2.

Bandwidth

The bandwidth of the probe is derived as a function of its rise time. The rise time (t_r) is measured in nanoseconds between the 10% and 90% points of the leading edge of the pulse. (Refer to the procedure on page 5–28.) To calculate the probe’s bandwidth, use the following formula:

$$\left(\frac{0.35}{t_r}\right) = \text{Bandwidth}$$

For example, a rise time of 175 ns would result in the following solution:

$$\left(\frac{0.35}{175 \times 10^{-9} \text{ seconds}}\right) = 2.0 \times 10^6 \text{ Hertz}$$

DC Accuracy



WARNING. *This test produces intense magnetic fields that may cause malfunctions in a normally operating heart pacemaker or damage sensitive equipment. Personnel fitted with pacemakers should not perform this test, and should stay at least 10 feet from the current loop while the test is being conducted.*

This procedure tests the DC accuracy of the A6304XL when used with the AM 503B and AM 5030. In this test you compare the voltage output of the Amplifier to a reference input. A multiple-turn current loop is used to keep the measured test current equivalent to a five-division signal for each current/division setting of the Amplifier.

Equipment Connections

1. Using a BNC cable, connect the Amplifier **OUTPUT** to a 50 Ω feedthrough termination. Attach the termination to a BNC-to-dual banana adapter. Taking care to observe the adapter polarity, insert the dual banana adapter into the digital multimeter DC voltage input.
2. Connect the current loop to the voltage/current source as shown in Figure 5–10.

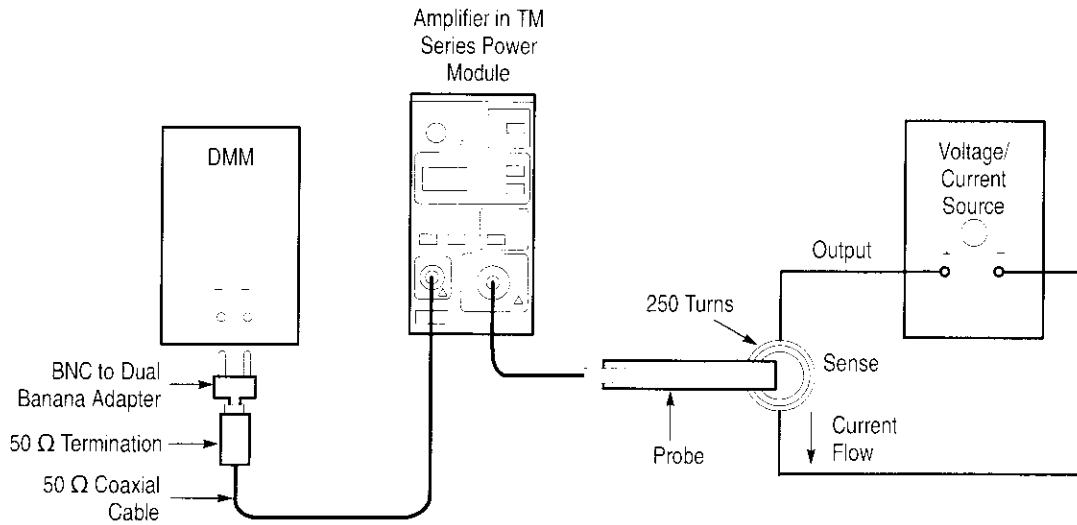

Figure 5–10: DC Accuracy Test Setup for the A6304XL

Equipment Settings

Make or check the equipment settings in Table 5–17:

Table 5–17: Equipment Settings for DC Accuracy

Digital Multimeter	
Measurement	DC volts
Voltage/Current Source	
Output	Off
Readout	Amps
Amps	Low
Current Limit	Minimum
Voltage Limit	2.0 V
AM 503B and AM 5030	
Coupling	DC
BW Limit	On
Current/division	500 mA/division



WARNING. This test produces intense magnetic fields that may cause malfunctions in a normally operating heart pacemaker or damage sensitive equipment. Personnel fitted with pacemakers should not perform this test, and should stay at least 10 feet from the current loop while the test is being conducted.

Procedure

1. Do not clamp the current probe around any conductor, but make sure the jaws are locked shut.
2. Press the Amplifier **PROBE DEGAUSS AUTOBALANCE** button. Wait for the degauss/autobalance routine to complete before proceeding. The routine is complete when the indicator light turns off.
3. Clamp the current probe around the current loop. Check that the arrow-shaped indicator on the probe points away from the current source. (See Figure 5-10 on page 5-31.)
4. For each of the Amplifier current/division settings in Table 5-18 on page 5-33, perform the following steps:
 - a. Check that the voltage/current source output is off.
 - b. Adjust the Amplifier **DC LEVEL** control counterclockwise to obtain a digital multimeter reading of approximately -25 mV (± 5 mV). Record the exact measurement as M_1 .
 - c. Turn on the voltage/current source output and adjust the output to obtain the current specified in Table 5-18.
 - d. Record the digital multimeter reading as M_2 .
 - e. Calculate the measured current (I_m) using the following formula:

$$I_m = \frac{M_2 - M_1}{0.01} \times (\text{current/division})$$

For example, you might have obtained values of -24.6 mA for M_1 and 25 mA for M_2 . If you are using an Amplifier setting of 10 A/division, you can compute I_m as:

$$I_m = \frac{(25.0 \times 10^{-3}) - (-24.6 \times 10^{-3})}{0.01} \times (10) = 49.6 \text{ A}$$

- f. Check that the measured current (I_m) is within $\pm 3\%$ of the test current (I_t) by computing $\%Error$ as follows:

$$\%Error = \frac{I_m - I_t}{I_t} \times 100$$

For example, using a test current I_t of 50 A and a measured current I_m of 49.6 A, the $\%Error$ would be:

$$\%Error = \frac{49.6 - 50.0}{50.0} \times 100 = -0.8\%$$

You can copy Table 5–19 on page 5–34 to record the results of your measurements.

Table 5–18: DC Accuracy Test for the A6304XL

Turns of Current Loop Passing Through Probe	AM 503B and AM 5030 Current/Division	Current/Voltage Source Output	Test Current I_t
250	500 mA	10 mA	2.5 A
250	1 A	20 mA	5 A
250	2 A	40 mA	10 A
250	5 A	100 mA	25 A
250	10 A	200 mA	50 A
250	20 A	400 mA	100 A
250	50 A	1.00 A	250 A
250	100 A	2.00 A	500 A
250	200 A	2.00 A	500 A

Table 5–19: DC Accuracy Test Worksheet for the A6304XL

Turns of Current Loop Passing Through Probe	AM 503B and AM 5030 Current/Division	Voltage/Current Source Output	Test Current I_t	M_1	M_2	I_m (Note A)	%Error (Note B)
250	500 mA	10 mA	2.5 A				
250	1 A	20 mA	5 A				
250	2 A	40 mA	10 A				
250	5 A	100 mA	25 A				
250	10 A	200 mA	50 A				
250	20 A	400 mA	100 A				
250	50 A	1 A	250 A				
250	100 A	2 A	500 A				
250	200 A	2 A	500 A				

Note A

$$I_m = \frac{M_2 - M_1}{0.01} \times (\text{current/division})$$

Note B

$$\%Error = \frac{I_m - I_t}{I_t} \times 100$$



Adjustment Procedures



Adjustment Procedures

Before performing the adjustment procedures, perform the following steps:

1. Install all plug-in units into the power modules.
2. Attach the current probe to be adjusted.
3. Turn the power on and allow the entire system to warm up for a minimum of 20 minutes. Also warm up any other test equipment used.

A6302 and A6302XL Adjustment

The following adjustment procedure describes how to adjust the DC offset of the A6302 and A6302XL. Tolerances that are specified in these procedures apply to the current probes and do not include test equipment error.

Required Test Equipment

To perform the adjustment procedure in this section, you will need the test equipment listed in Table 6-1. The test equipment must meet or exceed the specifications listed. The test procedure may need to be changed if the recommended equipment is not used.

Table 6-1: Required Test Equipment

Qty	Item	Description	Recommended Equipment
1	Oscilloscope	150 MHz bandwidth	TDS 460
1	Termination ¹	50 Ω , BNC connector, feedthrough	011-0049-01
3	BNC Cable ¹	50 Ω , 1.05 m (42 in) long	012-0057-01

¹ Provided as a standard accessory with the AM 503B and AM 5030.

A6302 and A6302XL DC Offset Adjustment

Figure 6-1 shows the location of the DC offset adjustment in the lower probe half.

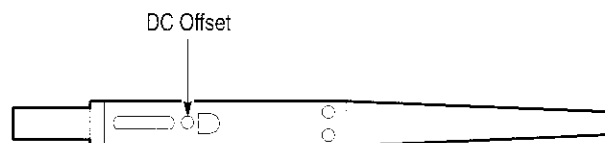

Figure 6-1: A6302 and A6302XL DC Offset Adjustment Location

Equipment Connections

1. Connect the Amplifier **OUTPUT** to a 50 Ω oscilloscope input using a 50 Ω BNC cable. If the input impedance of your oscilloscope is 1 M Ω , connect a 50 Ω feedthrough termination to the oscilloscope input. Do not connect the termination at the Amplifier output.

2. Connect the current probe to the Amplifier **INPUT** connector.
3. Do not clamp the current probe around any conductor, but make sure the jaws are locked shut.

Equipment Settings

Make or verify the equipment settings in Table 6–2:

Table 6–2: Settings for DC Offset Adjustment

AM 503B and AM 5030	
Coupling	DC
BW Limit	On (20 MHz bandwidth limit)
Current/division	10 mA/division
Oscilloscope	
Vertical Gain	10 mV/division
Time Base	1 ms/division, Auto triggered
Input Coupling	Ground

Procedure

1. Move the oscilloscope trace to the center horizontal graticule line using the vertical position control.
2. Set the oscilloscope input coupling to DC.
3. Do not clamp the current probe around any conductor, but make sure the jaws are locked shut.
4. Press the Amplifier **PROBE DEGAUSS AUTOBALANCE** button. Wait for the degauss/autobalance routine to complete before proceeding. The routine is complete when the indicator light turns off.

NOTE. The Amplifier front panel will display error code 266 after the degauss/autobalance routine completes if the Amplifier is not properly terminated into 50 Ω . Verify that the oscilloscope input is 50 Ω and set to DC coupling. If necessary, use a 50 Ω termination at the oscilloscope input.

5. If no error codes are displayed after the degauss/autobalance routine completes, no offset adjustment is necessary. If any of the error codes listed in Table 6–3 are displayed, continue with the procedure.

Table 6-3: Error Codes Requiring DC Offset Adjustment

Error Code	Meaning
580	Unable to complete negative offset adjustment
581	Unable to complete positive offset adjustment

6. Press and hold the **20 MHz BW LIMIT** button, and while holding it, press the **PROBE DEGAUSS AUTOBALANCE** button. This sets the front panel display to -00 and puts the AM 503B and AM 5030 into an internal test mode.
7. Press the **CURRENT/DIVISION** ∇ button until the front panel display reads -52.
8. Press and release the **20 MHz BW LIMIT** button. The Amplifier will degauss itself; wait until the DEGAUSS light goes out.
9. Adjust the DC Offset control so that the oscilloscope trace is on the center graticule line (zero offset), ± 1 division.
10. Press and release the **20 MHz BW LIMIT** button, then press and release the **COUPLING** button. This exits the AM 503B and AM 5030 test mode.

A6303 and A6303XL Adjustments

Each of the following adjustment procedures describes how to adjust specific performance characteristics of the A6303 and the A6303XL. Tolerances that are specified in these procedures apply to the current probes and do not include test equipment error.

Required Test Equipment

To perform the adjustment procedures in this section, you will need the test equipment listed in Table 6–4. The test equipment must meet or exceed the specifications listed. The test procedures may need to be changed if the recommended equipment is not used.

Table 6–4: Required Test Equipment

Qty	Item	Description	Recommended Equipment
1	Oscilloscope	150 MHz bandwidth	TDS 460
1	Calibration Generator	DC or 1 kHz square wave, 5 V _{p-p} into 50 Ω, 1% vertical accuracy	PG 506A
1	Current Loop	50 Ω	015–0601–50
1	Termination ¹	50 Ω, BNC connector, feedthrough	011–0049–01
3	BNC Cable ¹	50 Ω, 1.05 m (42 in) long	012–0057–01
1	BNC T-adaptor	50 Ω	103–0030–00

¹ Provided as a standard accessory with the AM 503B and AM 5030.

A6303 and A6303XL DC Offset Adjustment

This procedure describes how to adjust the DC offset of the A6303 and A6303XL using the DC Offset adjustment. Refer to Figure 6–2 when performing this procedure.

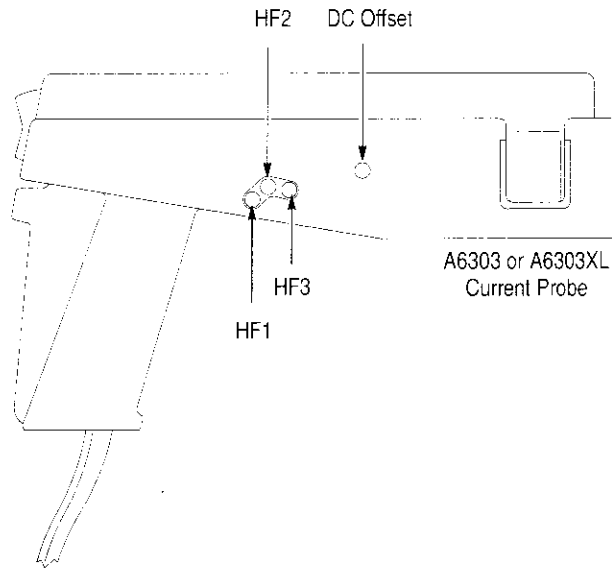

Figure 6–2: A6303 and A6303XL Adjustment Locations

Equipment Connections

1. Connect the Amplifier **OUTPUT** to a 50 Ω oscilloscope input using a 50 Ω BNC cable. If the input impedance of your oscilloscope is 1 M Ω , connect a 50 Ω feedthrough termination to the oscilloscope input. Do not connect the termination at the Amplifier output.
2. Connect the current probe to the Amplifier **INPUT** connector.
3. Do not clamp the current probe around any conductor, but make sure the jaws are locked shut.

Equipment Settings Make or verify the equipment settings in Table 6–5:

Table 6–5: Settings for DC Offset Adjustment

AM 503B and AM 5030	
Coupling	DC
BW Limit	Off (full bandwidth)
Current/division	10 mA/division
Oscilloscope	
Vertical Gain	10 mV/division
Time Base	1 ms/division, Auto triggered
Input Coupling	Ground

- Procedure**
1. Move the oscilloscope trace to the center horizontal graticule line using the vertical position control.
 2. Change the oscilloscope input coupling to DC.
 3. Do not clamp the current probe around any conductor, but make sure the jaws are locked shut.
 4. Press the Amplifier **PROBE DEGAUSS AUTOBALANCE** button. Wait for the degauss/autobalance routine to complete before proceeding. The routine is complete when the indicator light turns off.

NOTE. The Amplifier front panel will display error code 266 after the degauss/autobalance routine completes if the Amplifier is not properly terminated into 50 Ω . Verify that the oscilloscope input is 50 Ω and set to DC coupling. If necessary, use a 50 Ω termination at the oscilloscope input.

5. If no error codes are displayed after the degauss/autobalance routine completes, no offset adjustment is necessary. If any of the error codes listed in Table 6–6 are displayed, continue with the procedure:

Table 6–6: Error Codes Requiring DC Offset Adjustment

Error Code	Meaning
580	Unable to complete negative offset adjustment
581	Unable to complete positive offset adjustment

6. Remove the probe access plug for the DC Offset adjust (see Figure 6–2).

7. Press and hold the **20 MHz BW LIMIT** button, and while holding it, press the **PROBE DEGAUSS AUTOBALANCE** button. This sets the front panel display to –00 and puts the AM 503B and AM 5030 into an internal test mode.
8. Press the **CURRENT/DIVISION** \leftrightarrow button until the front panel display reads –52.
9. Press and release the **20 MHz BW LIMIT** button. The Amplifier will degauss itself; wait until the DEGAUSS light goes out.
10. Adjust the DC Offset control so that the oscilloscope trace is on the center graticule line (zero offset), ± 1 division.
11. Press and release the **20MHz BW LIMIT** button, then press and release the **COUPLING** button. This exits the AM 503B and AM 5030 test mode.

A6303 and A6303XL Transient Response and Gain Adjustment

This procedure describes how to optimize the transient response and gain of the A6303 and A6303XL using adjustments HF1, HF2, and HF3. Refer to figures 6–2 and 6–3 when performing this procedure.

NOTE. *The A6303XL has only a single adjustment located at the HF2 position.*

Equipment Connections

1. Connect the calibration generator output to a 50 Ω oscilloscope input using a 50 Ω BNC cable. If the input impedance of your oscilloscope is 1 M Ω , connect a 50 Ω feedthrough termination to the oscilloscope input. Do not connect the termination to the calibration generator output.
2. Connect the current probe to the Amplifier **INPUT** connector.

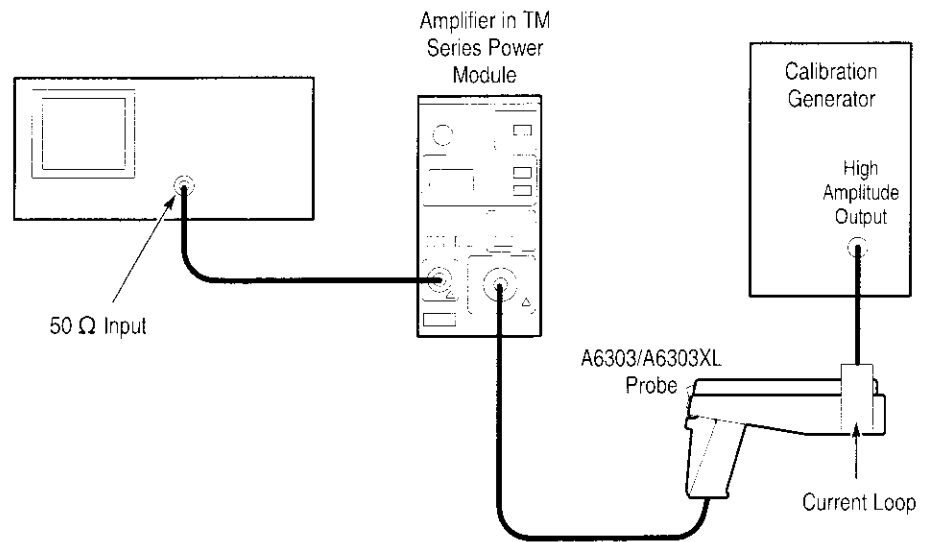

Figure 6–3: A6303 and A6303XL Adjustment Setup

Equipment Settings

Make or verify the equipment settings in Table 6–7:

Table 6–7: Settings for Transient Response and Gain Adjustments

AM 503B and AM 5030	
Coupling	DC
BW Limit	Off (full bandwidth)
Current/division	20 mA/division
Oscilloscope	
Vertical Gain	1 V/division
Time Base	100 μs/division, Auto triggered
Input Coupling	Ground
Calibration Generator	
Period	0.1 ms
Function	High amplitude

Procedure

1. Move the oscilloscope trace up one graticule line from the bottom of the screen.
2. Change the oscilloscope input coupling to DC.
3. Do not clamp the current probe around any conductor, but make sure the jaws are locked shut.

4. Press the Amplifier **PROBE DEGAUSS AUTOBALANCE** button. Wait for the degauss/autobalance routine to complete before proceeding. The routine is complete when the indicator light turns off.

NOTE. The Amplifier front panel will display error code **266** after the degauss/autobalance routine completes if the Amplifier is not properly terminated into $50\ \Omega$. Verify that the oscilloscope input is $50\ \Omega$ and set to DC coupling. If necessary, use a $50\ \Omega$ termination at the oscilloscope input.

5. Adjust the calibration generator to produce an amplitude of five graticule divisions (5 volts).

NOTE. Do not adjust the calibration generator amplitude for the remainder of this procedure.

6. Disconnect the BNC cable from the calibration generator and attach it to the Amplifier **OUTPUT** connector (see Figure 6–3).
7. Attach the current loop to the probe and lock the probe.
8. Connect the current loop to the calibration generator output using another coaxial cable.
9. Reset the vertical gain of the oscilloscope to 10 mV/division and the time base to 100 μ s/division.
10. Reset the period of the calibration generator to 1 ms.
11. Remove the probe access plugs for HF1, HF2, and HF3. Remove the HF2 plug only for the A6303 (see Figure 6–2).
12. Adjust the probe for optimum performance
 - A6303: Adjust HF1, HF2, and HF3 for an oscilloscope display of five divisions and optimum transient response.
 - A6303XL: Adjust only HF2 for an oscilloscope display of five divisions and optimum transient response. The A6303XL does not have controls in the HF1 and HF3 positions.

NOTE. The HF1, HF2, and HF3 adjustments on the A6303 interact. Adjusting them can be a repetitive process. You may need to balance between transient response and gain in order to meet both specifications at once.

Optional A6303 Gain Error Adjustment

NOTE. The procedure applies only to the A6303.

This procedure describes how to optimize the DC gain response of the A6303 current probes. The transient response adjustment must be completed before making the gain error adjustment.

1. Measure and record the resistance between pins M and J of the current probe connector. See Figure 6–4. Use the value measured for R_X in step 2.

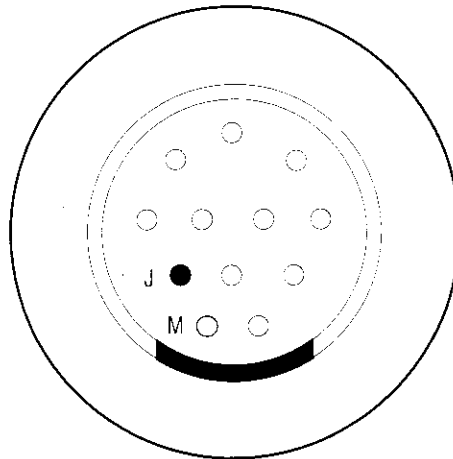

Figure 6–4: Current Probe Connector Configuration

2. Calculate the percent error using the following formula:

$$K = \frac{R_X}{R_X + 29.5}$$

$$\%Error = \frac{1 - 15935K}{25K + 14741} \times 100$$

The graph in Figure 6–5 can be used to approximate the error correction factor for the probe.

3. Connect the probe to the Amplifier.
4. Press and hold the **20 MHz BANDWIDTH LIMIT**, and press and release the **COUPLING** button.
5. Using the **CURRENT/DIVISION** \uparrow and \downarrow buttons, adjust the front panel display to reflect the error correction value.

NOTE. A display of 000 is the same as 1.000. A correction of -4% would require that the display read 960. A correction of +8% would require that the display read 080.

6. When the change is complete, press any button except the \uparrow or \downarrow buttons.

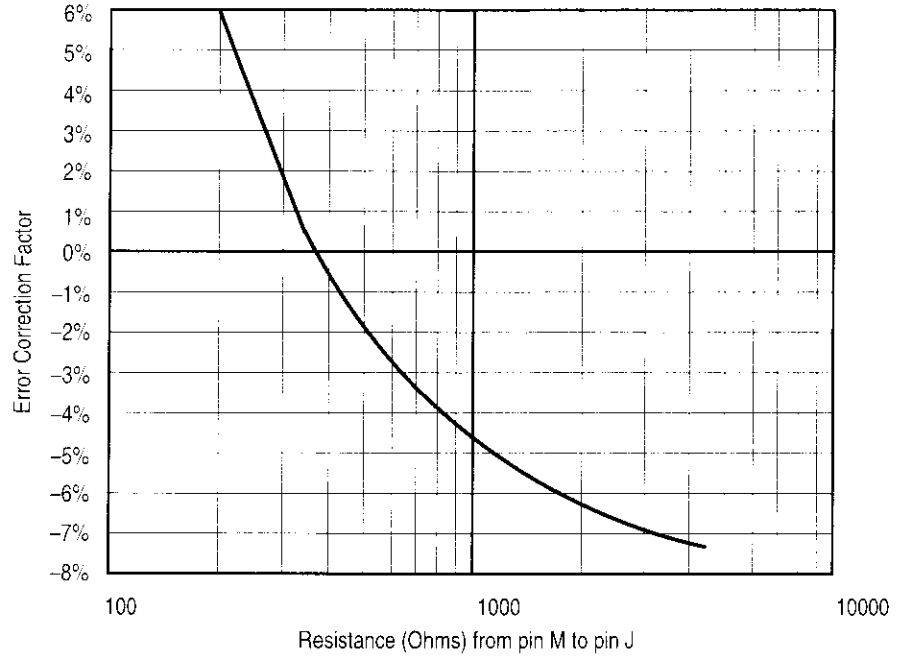

Figure 6-5: A6303 Gain Error Correction Curve

A6304XL Adjustments

Each of the following adjustment procedures describes how to adjust specific performance characteristics of the A6304XL. Tolerances that are specified in these procedures apply to the current probe and do not include test equipment error.

Required Test Equipment

To perform the adjustment procedures in this section, you will need the test equipment listed in Table 6–8. The test equipment must meet or exceed the specifications listed. The test procedures may need to be changed if Tektronix equipment is not used.

Read page 6–1 before starting these procedures. Also, read each procedure through completely before starting to ensure proper completion.

Table 6–8: Required Test Equipment

Qty	Item	Description	Recommended Example
1	Oscilloscope	20 MHz bandwidth	Tektronix TDS 460
1	Calibration Generator	Square wave with a rise time <35 ns, 5 A into 50 Ω	AVTECH ¹ AVR-3-PW-C-P-TEK2
1	Digital Multimeter	0.75% 3 ¹ / ₂ digit resolution	Tektronix DMM254
1	Power Supply with output meter	0–5 Amp 0.75% meter accuracy	Tektronix PS282
1	Current Loop	250 turns	067-0240-00
1	Termination ²	50 Ω , \pm 2%, 0.5 W	011-0049-01
3	BNC Cables ²	50 Ω , 1.05 m (42 in) long	012-0057-01
1	BNC to Dual Banana Adapter		103-0090-00

¹ AVTECH Electrosystems Ltd.
P.O. Box 265, Ogdensburg NY 13669-0265
(315) 472-5270 or (800) 265-6681

² One provided as a standard accessory with the AM 503B and AM 5030.

A6304XL DC Offset Adjustment

This procedure details how to adjust the A6304XL offset.

Equipment Connections

1. Connect the Amplifier **OUTPUT** to a 50 Ω oscilloscope input using a 50 Ω BNC cable. If the input impedance of your oscilloscope is 1 MΩ, connect a 50 Ω feedthrough termination to the oscilloscope input. Do not connect the termination at the Amplifier output.
2. Connect the current probe to the Amplifier **INPUT** connector.
3. Do not clamp the current probe around any conductor, but make sure the jaws are locked shut.

Equipment Settings

Make or verify the equipment settings in Table 6–9:

Table 6–9: Settings for DC Offset Adjustment

AM 503B and AM 5030	
Coupling	DC
BW Limit	Off (full bandwidth)
Current/division	1 A/division
Oscilloscope	
Vertical Gain	10 mV/division
Time Base	1 ms/division, Auto triggered
Input Coupling	Ground

Procedure

1. Move the oscilloscope trace to the center horizontal graticule line using the vertical position control.
2. Change the oscilloscope input coupling to DC.
3. Do not clamp the current probe around any conductor, but make sure the jaws are locked shut.
4. Press the Amplifier **PROBE DEGAUSS AUTOBALANCE** button. Wait for the degauss/autobalance routine to complete before proceeding. The routine is complete when the indicator light turns off.

NOTE. The Amplifier front panel will display error code 266 after the degauss/autobalance routine completes if the Amplifier is not properly terminated into 50 Ω. Verify that the oscilloscope input is 50 Ω and set to DC coupling. If necessary, use a 50 Ω termination at the oscilloscope input.

5. If no error codes are displayed after the degauss/autobalance routine completes, no offset adjustment is necessary. Go to the DC Accuracy adjustment on page 6–18.
6. If either of the error codes in Table 6–10 are displayed, continue with this procedure.

Table 6–10: Error Codes Requiring DC Offset Adjustment

Error Code	Meaning
580	Unable to complete negative offset adjustment
581	Unable to complete positive offset adjustment

7. Remove the probe access plug for the DC Offset adjust (see Figure 6–6).

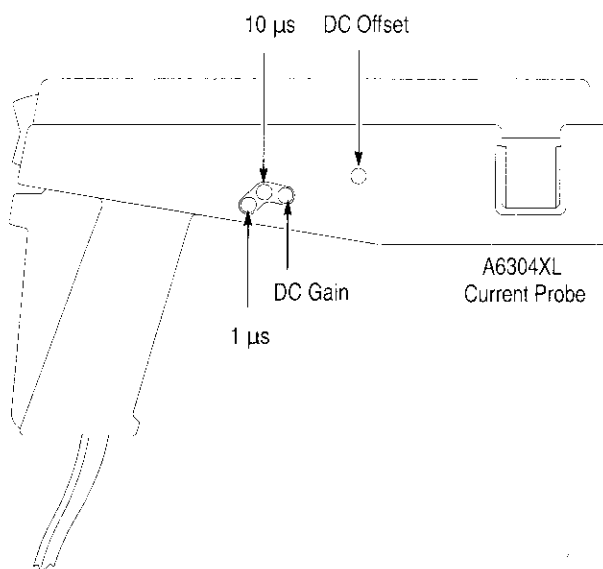

Figure 6–6: A6304XL Adjustment Locations

8. Press and hold the **20 MHz BW LIMIT** button, and while holding it, press the **PROBE DEGAUSS AUTOBALANCE** button. This sets the front panel display to –00 and puts the AM 503B and AM 5030 into an internal test mode.
9. Press the **CURRENT/DIVISION** \leftrightarrow button until the front panel display reads –52.
10. Press and release the **20 MHz BW LIMIT** button. The Amplifier will degauss the probe; wait until the DEGAUSS light goes out.

11. Adjust the DC Offset control so that the oscilloscope trace is on the center graticule line (zero offset), ± 1 division.
12. Press and release the **20MHz BW LIMIT** button, then press and release the **COUPLING** button. This exits the AM 503B and AM 5030 test mode.

DC Gain Adjustment

This procedure adjusts the DC accuracy of the A6304XL probe.



CAUTION. *This test produces magnetic fields that may cause a malfunction in normally operating heart pacemakers or damage sensitive equipment. Personnel fitted with pacemakers should not perform this test and should stay at least 10 feet from the current loop while the test is being conducted.*

Equipment Settings

Make or check the equipment settings in Table 6–11:

Table 6–11: Equipment Settings for DC Accuracy

Digital Multimeter	
Measurement Type	DC volts
Voltage/Current Source	
Output	Off
Current Limit	Minimum
Voltage	2.0 V
AM 503B and AM 5030	
Coupling	DC
BW Limit	On
Current/division	10 A/division

Equipment Connections

1. Using a BNC cable, connect the Amplifier **OUTPUT** to a 50 Ω feedthrough termination. Attach the termination to a BNC-to-dual banana adapter. Taking care to observe the adapter polarity, insert the dual banana adapter into the digital multimeter DC voltage input.
2. Connect the current loop to the voltage/current source as shown in Figure 6–7.

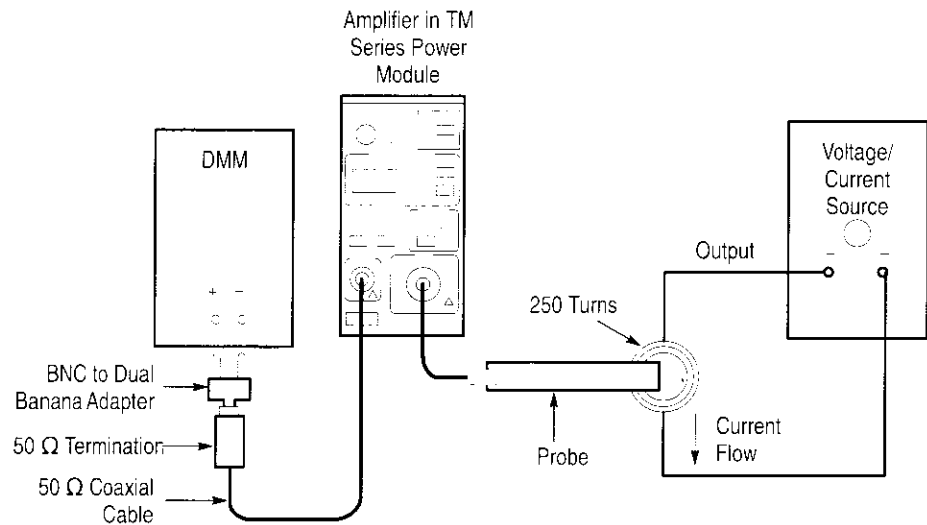

Figure 6–7: DC Accuracy Adjustment Setup

Procedure

1. Do not clamp the current probe around any conductor, but make sure the jaws are locked shut.
2. Press the Amplifier **PROBE DEGAUSS AUTOBALANCE** button. Wait for the degauss/autobalance routine to complete before proceeding. The routine is complete when the indicator light turns off.
3. If necessary, adjust **DC LEVEL** on the amplifier for a zero reading on the DMM.
4. Clamp the current probe around the current loop. (See Figure 6–7.) Check that the arrow-shaped indicator on the probe points away from the current source.
5. Adjust the current output of the power supply to 200 mA.
6. The DMM reading should be 50 mV. If you could not set your power supply to exactly 200 mA, use the formula below:

$$\text{DMM voltage reading} = \frac{\text{current source reading} \times 250 \text{ turns}}{10 \text{ Amps/division}} \times 10 \text{ mV/division}$$

7. If the reading is not correct, adjust **DC GAIN** on the A6304XL for a correct reading on the DMM. See Figure 6–6 on page 6–17.

A6304XL Transient Response Adjustment

This procedure describes how to optimize the transient response of the A6304XL using the 10 μ s and 1 μ s adjustments. Refer to figures 6–6 and 6–8 when performing this procedure.

Equipment Connections

1. Connect the Amplifier output to a 50 Ω oscilloscope input using a 50 Ω BNC cable. If the input impedance of your oscilloscope is 1 M Ω , connect a 50 Ω feedthrough termination to the oscilloscope input.
2. Connect the current probe to the Amplifier **INPUT** connector.

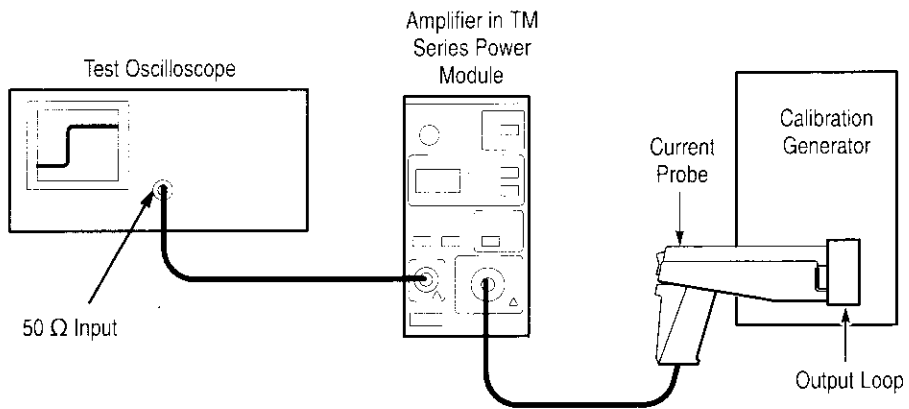

Figure 6–8: A6304XL Adjustment Setup

Equipment Settings

Make or verify the equipment settings in Table 6–12:

Table 6–12: Equipment Settings for Transient Response

Oscilloscope	
Vertical input impedance	50 Ω
Vertical gain	10 mV/division
Time base	100 μ s/division
Record length	500
Coupling	DC
Offset	0 V (mid-scale)
Trigger type	Edge
Trigger mode	Normal
Trigger position	50%
Acquisition mode	Average
Number of waveforms to average	8
Measurement type	Rise Time

Table 6–12: Equipment Settings for Transient Response (Cont.)

Calibration Generator	
Pulse Width	250 μ s
Pulse Repetition Frequency	20 Hz
Pulse Amplitude	5 A peak
AM 503B and AM 5030	
Coupling	DC
BW Limit	Off
Current/division	1 A/division

Procedure

1. Move the oscilloscope trace to one graticule line from the bottom of the screen.
2. Set the oscilloscope input coupling to DC.
3. Do not clamp the current probe around any conductor, but make sure the jaws are locked shut.
4. Remove the probe access plugs for 1 μ s, 10 μ s, and DC Gain.
5. Press the Amplifier **PROBE DEGAUSS AUTOBALANCE** button. Wait for the degauss/autobalance routine to complete before proceeding. The routine is complete when the indicator light turns off.

NOTE. The Amplifier front panel will display error code **266** after the degauss/autobalance routine completes if the Amplifier is not properly terminated into 50 Ω . Verify that the oscilloscope input is 50 Ω and set to DC coupling. If necessary, use a 50 Ω termination at the oscilloscope input.

6. Lock the jaws of the probe around the calibrator current loop.
7. Adjust the oscilloscope to view the 100 μ s portion of the pulse.
8. Adjust the calibration generator to produce an amplitude of five graticule divisions (5 amps) at the 100 μ s portion of the pulse.

NOTE. Do not adjust the calibration generator amplitude for the remainder of this procedure.

9. Adjust the **10 μ s** control for a flat waveform to match the level at the 100 μ s point.
10. Adjust the oscilloscope sweep to 1 μ s/div.

11. Adjust the **1 μ s** control to flatten the front end of the pulse.

NOTE. *The 10 μ s and 1 μ s adjustments on the A6304XL interact. Adjusting them can be a repetitive process. You may need to balance between short and long term response in order to meet both specifications at once.*

12. Disconnect the probe from the calibration generator current loop.

13. Repeat the DC Accuracy adjustment procedure on page 6–18.

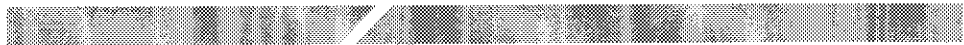

Maintenance

Customer Maintenance

This manual supports maintenance of the AM 503B and AM 5030 only. For detailed information on servicing the current probes, refer to the *Instructions* provided with the probe.

Service Strategy

The AM 503B and AM 5030 have few customer-serviceable parts and should be returned to a Tektronix Service Center in the event of failure. Some mechanical and electrical parts may be replaced by the customer. This section describes the preventive maintenance and repair procedures.

Preventive Maintenance

The AM 503B and AM 5030 Current Probe Amplifiers and current probes require little maintenance during normal use. The primary maintenance involves cleaning accumulated dirt from the probe body and, if necessary, cleaning the exposed core surfaces in the probe jaw.

To clean the probe body, use a soft cloth dampened in a solution of mild detergent and water.

To clean the core, open the jaw and clean the exposed core surfaces with a cloth.



CAUTION. Avoid using chemical cleaning agents that damage plastic. For example, avoid using chemicals that contain benzene, toluene, xylene, acetone, or similar solvents. Recommended cleaning agents are isopropyl alcohol (Isopropanol) or ethyl alcohol (Fotocol or Ethanol).

Disassembly

Use these procedures when repairing or replacing defective components. For disassembly instructions pertaining to the TM Series Power Module, refer to that Instruction Manual.

Static Device Precautions



CAUTION. *Static discharge can damage semiconductors in the AM 503B and AM 5030. Observe the following precautions:*

- Minimize handling of static-sensitive devices.
- Transport and store static-sensitive components or assemblies in their original containers, either on a metal surface or conductive foam. Label any package that contains static-sensitive assemblies or components.
- Wear a wrist strap while handling these components to discharge the static voltage from your body. Servicing static-sensitive assemblies or components should be performed only at a static-free work station. The use of a static control mat is recommended.
- Clear anything from the work station surface that is capable of generating or holding static charge.
- Keep component leads shorted together whenever possible.
- Pick up components by the body, never by the leads.
- Do not slide components over any surface.
- Avoid handling components in areas that have a floor or a work surface that is capable of generating static charge.

Front Panel Knobs

To remove the front panel knob simply pull the knob off. The shaft will come off with the knob.

To reinstall the knob, align the slotted end of the shaft with the rib inside the knob. Push the knob onto the shaft.

Side Covers

To remove the side covers, turn the securing screw 90° counterclockwise and pull the cover off, as shown in Figure 7-1. To reassemble, reverse the procedure.

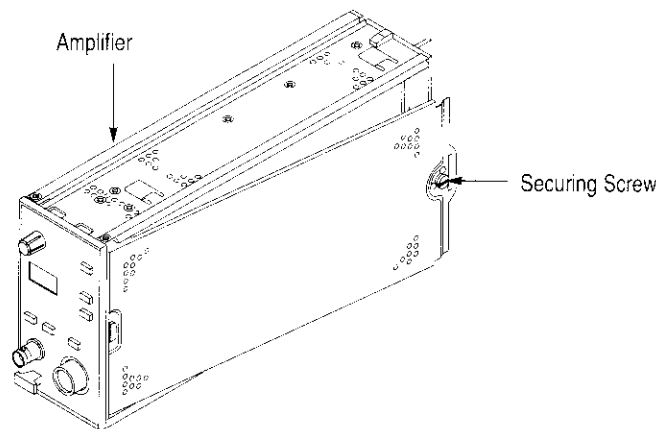

Figure 7-1: Removing the AM 503B and AM 5030 Side Covers

Front Panel and Release Lever Assembly



CAUTION. The AM 503B and AM 5030 contain devices that are susceptible to damage from static discharge. To prevent damage to static-sensitive devices, observe the precautions listed at the beginning of this section whenever the covers are off the instrument or you handle component assemblies.

In order to remove the front panel assembly, the release lever must be removed. Perform steps 1 through 4 to remove the front panel assembly. If you want to repair the release lever assembly, complete all the steps.

The release lever assembly consists of the release lever, latch bar, and retaining latch. These procedures describe how to remove and replace each item.

1. Remove the left side cover (when facing the front of the Amplifier).

2. Push the latch bar forward as shown in Figure 7–2. Pry the back end of the release lever up and pull the release lever through the front panel.

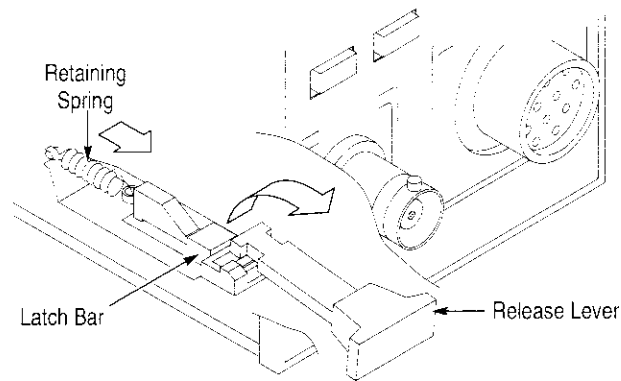

Figure 7–2: Removing the Amplifier Release Lever

3. Unplug the input, output, and front panel interface cables from the main circuit board. Figure 7–3 shows the location of these cables.

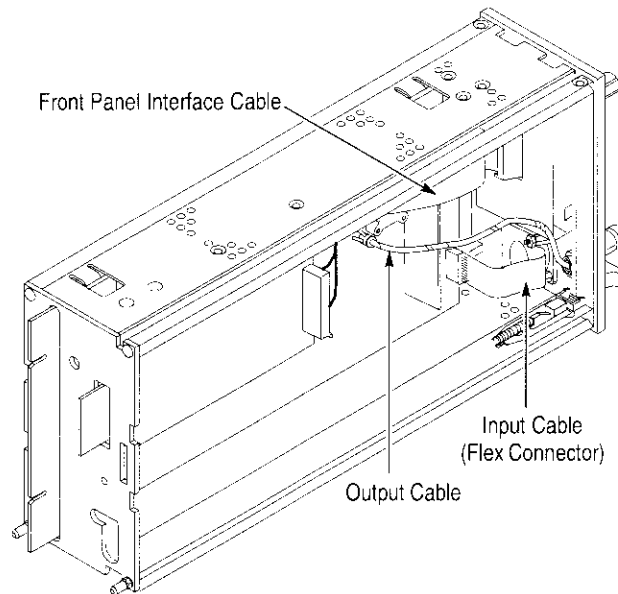

Figure 7–3: Location of Amplifier Interface Cables

- Using a Pozidriv #1 screwdriver, remove the two top screws and the two bottom screws that hold on the front panel and remove the front panel. Figure 7-4 shows the screw locations.

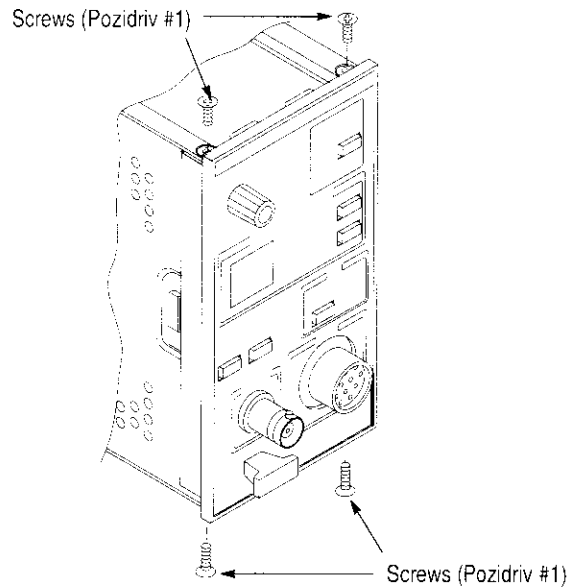

Figure 7-4: Location of Front Panel Screws

- Using a spring hook or a pair of needle-nose pliers, remove the retaining spring. Refer to Figure 7-2.
- Push the latch bar forward until it clears the the retaining latch. Refer to Figure 7-5.
- Push the retaining latch upward past the retaining clip.
- To reassemble, reverse this procedure.

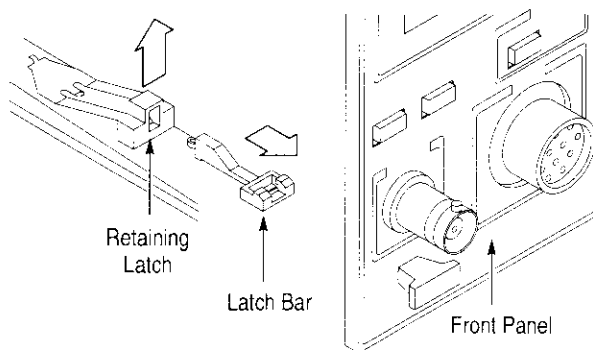

Figure 7-5: Removing the Latch Bar Assembly

Front Panel Disassembly

This procedure describes how to disassemble and reassemble the front panel assembly. Refer to Figures 7-6 and 7-7 when performing this procedure.

1. Remove the front panel from the Amplifier chassis (described earlier).
2. Remove the knob by firmly pushing against shaft from the rear of the panel.
3. Unplug the Peltola connector from the back of the BNC connector.
4. Using a $\frac{1}{2}$ inch wrench, remove the retaining nut on the back of the BNC connector and remove the washer.
5. Pull the BNC connector out of the front panel. (To reassemble, align the flat spot of the connector's threaded end with the flat spot of the front panel hole and push the connector into the front panel. Perform steps 1 through 3 in reverse order.)

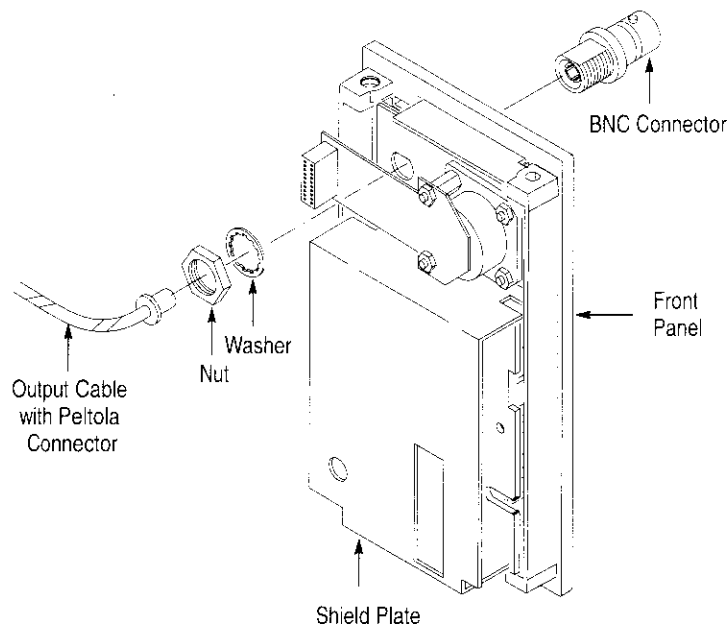

Figure 7-6: Removing the Amplifier Output Connector

6. Slide the shield plate and input connector assembly down and lift it out of the way.
7. Unsnap the three retaining clips holding the front panel circuit board in place and lift the board out of the panel.
8. To reassemble, reverse this procedure

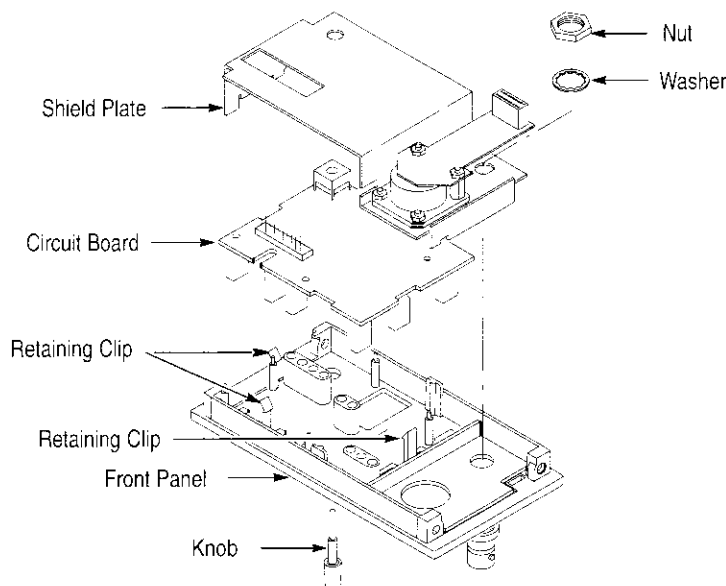

Figure 7-7: Removing the Amplifier Front Panel Board

Using the Rear Interface Output Connector

Some Power Modules support an option to reroute the plug-in instrument output to the rear interface of the power module (refer to the Tektronix catalog or contact your Tektronix sales representative). You can configure the AM 503B and AM 5030 for this type of power module by following these steps. Refer to Figure 7-8 as necessary.

NOTE. *If you use the power module rear interface connector, high frequency performance may be degraded, depending on your system configuration. If high frequency performance is critical, route a BNC cable from the front panel OUTPUT connector to your system.*

1. Remove the left side cover.
2. Locate the output cable with the Peltola connector that plugs into the rear of the front panel BNC output connector. Refer to Figure 7-8.
3. Carefully withdraw the output cable from the BNC output connector.
4. AM 5030 only: Using a Torx #T-10 screwdriver, remove the three screws holding the GPIB circuit board in place. Slide the board towards the front panel until the edge connector is free, and then lift the card out of the way.
5. Taking care to prevent damage to the easily bent center conductor, insert the output cable into the rear interface output connector as shown in Figure 7-8.

6. AM 5030 only: Replace the GPIB circuit board by guiding the edge connector through the back plane and replacing the three hold-down screws.
7. To restore instrument output to the front panel BNC output connector, reverse the procedure.

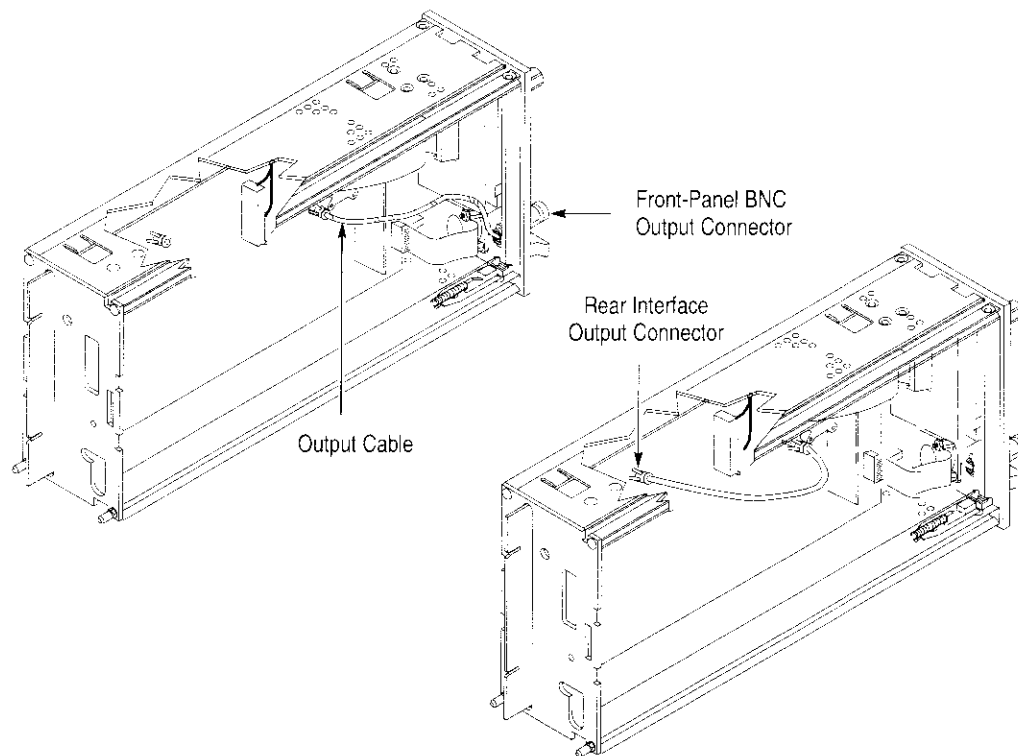

Figure 7-8: Using the Rear Interface Output Connector

Battery Replacement

This procedure describes how to replace the Amplifier backup battery.

1. Using a small flat-blade screwdriver, gently pry against the battery terminal as shown in Figure 7-9 until the battery just starts to slide out.



CAUTION. Avoid using excessive force when prying against the battery terminal. Excessive force can damage the spring tension of the terminal, resulting in poor battery contact or no contact at all.

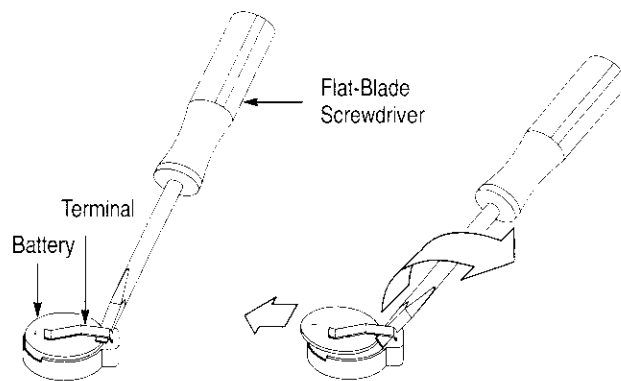

Figure 7-9: Prying Battery Terminal to Remove Battery

2. Once the battery starts to slide out, push against the edge of the battery with the screwdriver blade until the battery is completely out. Figure 7-10 illustrates this action.

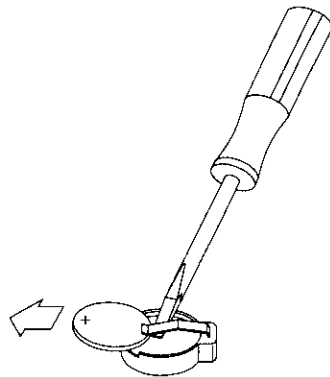

Figure 7-10: Removing the Backup Battery

3. To replace the battery, gently pry up on the battery terminal as shown in Figure 7-11 and push the battery into place.



CAUTION. *Observe the proper polarity for the battery. The + side should be exposed on top. Improper polarity can damage the instrument.*

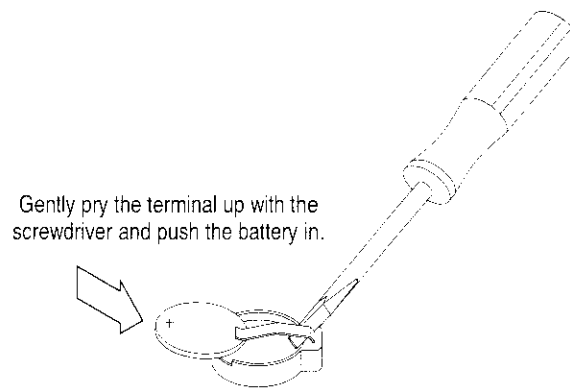

Figure 7-11: Replacing the Backup Battery



Replaceable Mechanical Parts



Replaceable Parts

This section contains a list of the components that are replaceable for the AM 503B and AM 5030. As described below, use these lists to identify and order replacement parts.

Parts Ordering Information

Replacement parts are available from or through your local Tektronix, Inc., service center or representative.

Changes to Tektronix instruments are sometimes made to accommodate improved components as they become available and to give you the benefit of the latest circuit improvements. Therefore, when ordering parts, it is important to include the following information in your order:

- Part number
- Instrument type or model number
- Instrument serial number
- Instrument modification number, if applicable

If a part you order has been replaced with a different or improved part, your local Tektronix service center or representative will contact you concerning any change in the part number.

Using the Replaceable Parts List

The tabular information in the Replaceable Parts List is arranged for quick retrieval. Understanding the structure and features of the list will help you find all the information you need for ordering replacement parts.

Item Names

In the Replaceable Parts List, an Item Name is separated from the description by a colon (:). Because of space limitations, an Item Name may sometimes appear as incomplete. For further Item Name identification, U.S. Federal Cataloging Handbook H6-1 can be used where possible.

Indentation System

This parts list is indented to show the relationship between items. The following example is of the indentation system used in the Description column:

1	2	3	4	5	Name & Description
					Assembly and/or Component
					Attaching parts for Assembly and/or Component (END ATTACHING PARTS)
					Detail Part of Assembly and/or Component
					Attaching parts for Detail Part (END ATTACHING PARTS)
					Parts of Detail Part
					Attaching parts for Parts of Detail Part (END ATTACHING PARTS)

Attaching parts always appear at the same indentation as the item it mounts, while the detail parts are indented to the right. Indented items are part of, and included with, the next higher indentation. Attaching parts must be purchased separately, unless otherwise specified.

Abbreviations

Abbreviations conform to American National Standards Institute (ANSI) standard Y1.1.

AM 503B & AM 5030 Replaceable Parts

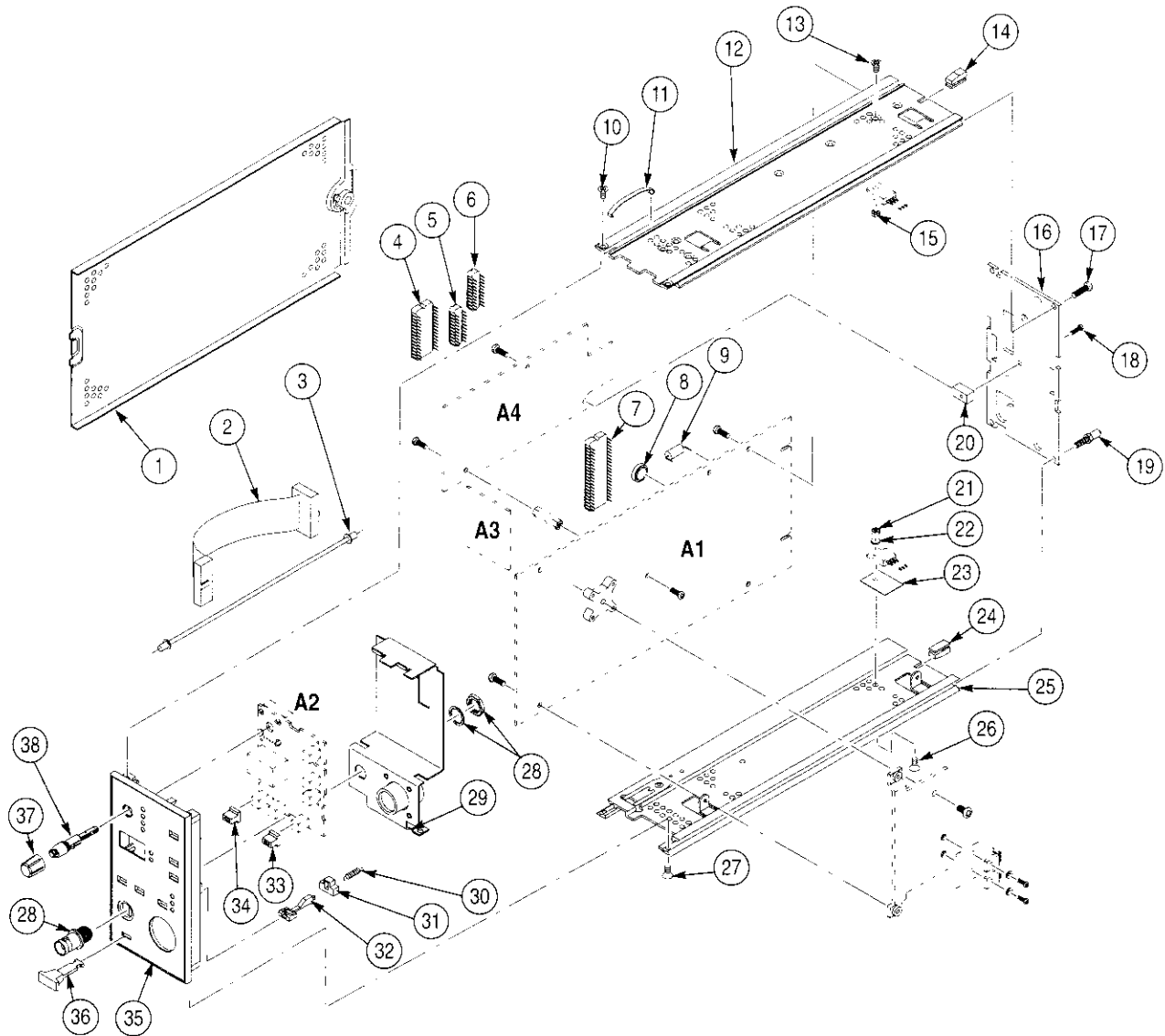

Figure 8-1: AM 503B & AM 5030 Replaceable Parts

AM 503B & AM 5030 Replaceable Parts

Fig. & Index No.	Tektronix Part No.	Serial No. Effective	Dscont	Qty	12345 Name & Description	Mfr. Code	Mfr. Part No.
8-1-1	337-3211-00			2	SHIELD,ELEC:SIDE ASSEMBLY	TK1465	ORDER BY DESC
-2	174-2314-00			2	CA ASSY,SPELEC:20,28 AWG,6.0 L.FLAT (AM5030 ONLY)	53387	ORDER BY DESC
	174-2314-00			1	CA ASSY,SPELEC:20,28 AWG,6.0 L.FLAT (AM503B ONLY)	53387	ORDER BY DESC
-3	175-5534-00			1	CABLE ASSY,RF:50 OHM COAX,6.25L, 9-2,PELTOLA X PELTOLA	80009	175553400
-4	160-9565-01			1	IC,MEMORY:CMOS,EPRM:32K X 8.PRGM 156-3503-00,27C256,DIP28.6.GPIB ROM,200NS (AM5030 ONLY)	80009	160956501
-5	156-1415-00			1	IC.DIGITAL:LS TTL,TRANSCEIVER;OCTAL IEEE-488GPIB BUS MGT (AM5030 ONLY)	01295	SN75161BN
-6	156-1414-00			1	IC.DIGITAL:LS TTL,TRANSCEIVER;OCTAL IEEE-488GPIB BUS XCVR (AM5030 ONLY)	01295	SN75160BN
-7	160-9569-00	B010001	B010099	1	IC.PROCESSOR:CMOS,MICROCOMPUTER; 8-BIT,16MHZ,32K X 8 OTP EPROM,512 X 8 RAM (AM5030 ONLY)	80009	160956900
	160-9569-01	B010100	B019999	1	IC.PROCESSOR:CMOS,MICROCOMPUTER; 8-BIT,16MHZ,32K X 8 OTP EPROM,512 X 8 RAM (AM5030 ONLY)	80009	160956901
	160-9569-01	B010000	B019999	1	IC.PROCESSOR:CMOS,MICROCOMPUTER; 8-BIT,16MHZ,32K X 8 OTP EPROM,512 X 8 RAM (AM503B ONLY)	80009	160956901
	160-9569-02	B020000		1	IC.PROCESSOR:CMOS,MICROCOMPUTER; 8-BIT,16MHZ,32K X 8 OTP EPROM,512 X 8 RAM (AM503B AND AM5030)	80009	160956902
-8	146-0087-00			1	BATTERY,DRY:1.5V,SILVER OXIDE,600MAH,2/3 AA SIZE W/PC TABS	61058	SP389
-9	159-0204-00			5	FUSE,WIRE LEAD:3.0A,125V,5 SECONDS	61857	SP7-3A
-10	211-0101-00			2	SCREW,MACHINE:4-40 X 0.25,FLH,100 DEG,STL	TK0435	ORDER BY DESC
-11	214-3406-00			1	SPRING,FLAT:1.48 L X 0.125 W,CU BE	TK1326	ORDER BY DESC
-12	426-0725-24			1	FR SECT,PLUG-IN:TOP	TK1465	ORDER BY DESC
-13	211-0101-00			1	SCREW,MACHINE:4-40 X 0.25,FLH,100 DEG,STL	TK0435	ORDER BY DESC
-14	214-3089-01			1	LOCKOUT,PLUG-IN:PLASTIC (AM5030 ONLY)	0JR05	ORDER BY DESC
-15	210-0406-00			1	NUT,PLAIN,HEX:4-40 X 0.188,BRS CD PL	73743	12161-50
-16	386-4910-00			1	SUPPORT,FRAME:REAR	TK1943	ORDER BY DESC
-17	213-0882-00			2	SCREW,TPG,TR:6-32 X 0.437 TAPTITE,PNH,STL	0KB01	ORDER BY DESC
-18	211-0408-00			1	SCR,ASSEM WSHR:4-40 X 0.250,PNH,STL TORXT10 (AM5030 ONLY)	93907	829-06815-024
-19	386-3657-01			2	SUPPORT,PLUG-IN:	83486	ORDER BY DESC
-20	220-0729-00			1	NUT BLOCK:4-40 X 0.188,BRS NP (AM5030 ONLY)	80009	220072900
-21	210-0406-00			2	NUT,PLAIN,HEX:4-40 X 0.188,BRS CD PL	73743	12161-50

Fig. & Index No.	Tektronix Part No.	Serial No.		Qty	12345 Name & Description	Mfr. Code	Mfr. Part No.
		Effective	Dscont				
-22	210-1178-00			2	WASHER,SHLDR:U/W TO-220 TRANSISTOR	13103	7721-7PPS
-23	342-0967-00			2	INSULATOR,PLATE:TRANSISTOR,SILCONE RUBBER WITH ADHESIVE	80009	342096700
-24	214-3089-01			1	LOCKOUT,PLUG-IN:PLASTIC (AM5030 ONLY)	0JR05	ORDER BY DESC
-25	426-0724-30			1	FR SECT,PL-IN:BOTTOM	TK1465	ORDER BY DESC
-26	211-0101-00			2	SCREW,MACHINE:4-40 X 0.25,FLH,100 DEG.STL	TK0435	ORDER BY DESC
-27	211-0101-00			2	SCREW,MACHINE:4-40 X 0.25,FLH,100 DEG.STL	TK0435	ORDER BY DESC
-28	131-1315-01			1	CONN,RF JACK:BNC/PNL,,50 OHM,FEMALE, STR,PELTOLA/REAR PNL,SILVER/BRIGHT ALLOY,0.576 MLGX 0.366 TERMN,0.375-32 THD,D-FLAT	24931	28JR306-1
-29	337-3927-01			1	SHIELD,ELEC AS:W/CONNECTOR & FLEX BOARD	80009	337392701
-30	214-3143-00			1	SPRING,HLEXT:0.125 OD X 0.545 L,XLOOP	8X345	ORDER BY DESC
-31	105-0866-00			1	LATCH,RETAINING:	0JR05	ORDER BY DESC
-32	105-0865-00			1	BAR,LATCH RLSE:	0JR05	ORDER BY DESC
-33	366-0733-00			3	KNOB,KEYCAP:UNLIT	0KBZ5	ORDER BY DESC
-34	366-0732-00			3	KNOB,KEYCAP:LIGHTED (AM5030 ONLY)	0KBZ5	ORDER BY DESC
	366-0732-00			2	KNOB,KEYCAP:LIGHTED (AM503B ONLY)	0KBZ5	ORDER BY DESC
-35	386-0050-01	B010001	B010019	1	PANEL,FRONT:W/ID LABEL (AM5030 ONLY)	80009	386005001
	614-0926-00	B010020		1	FR PANEL ASSY: W/ID LABEL (AM5030 ONLY)	80009	614092600
	614-0924-00			1	FR PANEL ASSY: W/ID LABEL (AM503B ONLY)	80009	614092400
-36	366-1851-02			1	KNOB,LATCH:IVORY GRAY, POLYCARBONATE,1.09 X 0.250	0JR05	ORDER BY DESC
-37	366-2111-00			1	KNOB:SMALL,FLUTED	TK1163	ORDER BY DESC
-38	384-1695-00			1	SHAFT,EXTENSION:1.550 L,0.264 DIA,DELTRIN	80009	384169500

AM 503B & AM 5030 Replaceable Parts

Fig. & Index No.	Tektronix Part No.	Serial No. Effective Dscont	Qty	12345 Name & Description	Mfr. Code	Mfr. Part No.
STANDARD ACCESSORIES						
-1	011-0049-01		1	TERMN,COAXIAL;50 OHM,2W,BNC	64537	T132DS
-2	012-0057-01		1	CA ASSY,RF;COAXIAL,;RFD,50 OHM,43 L, BNC,MALE,STR,BOTH ENDS,W/STRAIN RELIEF BOOT BOTH ENDS	80009	012005701
	070-8766-01		1	MANUAL,TECH:INSTR,AM503B/AM5030	80009	070876601
	070-8770-01		1	MANUAL,TECH:REF AM503B/AM5030	80009	070877001
OPTIONAL ACCESSORIES						
	015-0601-50		1	ADAPTER:1 TURN CURRENT LOOP;50 OHM	64537	JA-120S
	012-0991-00			CABLE,INTCON;SHLD CMPST,GPIB;CRC,12 TW PR,24,28 AWG,2 METER,DUAL SHIELD,24 POS, 0.085 CTR,RIBBON,FEEDTHRU,BOTH ENDS	22526	81190-020

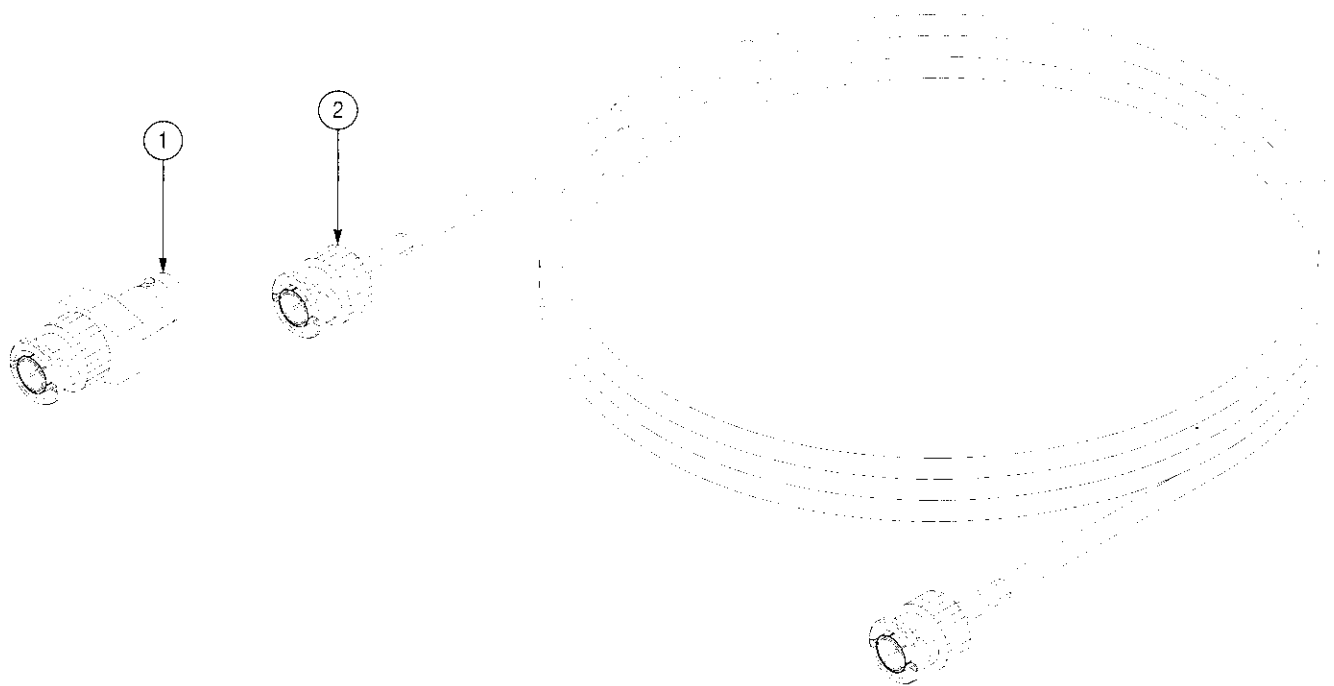

Figure 8-2: AM 503B & AM 5030 Standard Accessories

CROSS INDEX – MFR. CODE NUMBER TO MANUFACTURER

Mfr. Code	Manufacturer	Address	City, State, Zip Code
TK0392	NORTHWEST FASTENER SALES INC	7923 SW CIRRUS DRIVE	BEAVERTON OR 97005–6448
TK0435	LEWIS SCREW CO	4300 S RACINE AVE	CHICAGO IL 60609–3320
TK1163	POLYCAST INC	9898 SW TIGARD ST	TIGARD OR 97223
TK1326	NORTHWEST FOURSLIDE INC	18224 SW 100TH CT	TUALATIN OR 97062
TK1465	BEAVERTON PARTS MFG CO	1800 NW 216TH AVE	HILLSBORO OR 97124–6629
TK1943	NEILSEN MANUFACTURING INC	3501 PORTLAND ROAD NE	SALEM OR 97303
0JR05	TRIQUEST CORP	3000 LEWIS AND CLARK HWY	VANCOUVER WA 98661–2999
0KBZ5	MORELLIS Q & D PLASTICS	1812 16TH AVE	FOREST GROVE OR 97116
0KB01	STAUFFER SUPPLY	810 SE SHERMAN	PORTLAND OR 97214
00779	AMP INC	2800 FULLING MILL, PO BOX 3608	HARRISBURG PA 17105
01295	TEXAS INSTRUMENTS INC SEMICONDUCTOR GROUP	13500 N CENTRAL EXPY PO BOX 655303	DALLAS TX 75262–5303
02768	ILLINOIS TOOL WORKS INC FASTEX DIVISION	195 ALGONQUIN ROAD	DES PLAINES IL 60016–6103
04811	PRECISION COIL SPRING CO	10107 ROSE ST, PO BOX 5450	EL MONTE CA 91734
05469	BEARINGS INC	3634 EUCLID, PO BOX 6925	CLEVELAND OH 44101
12327	FREEWAY CORP	9301 ALLEN DR	CLEVELAND OH 44125–4632
13103	THERMALLOY CO INC	2021 W VALLEY VIEW LN PO BOX 810839	DALLAS TX 75381
22526	BERG ELECTRONICS INC (DUPONT)	857 OLD TRAIL RD	ETTERS PA 17319
24931	SPECIALTY CONNECTOR CO INC	2100 EARLYWOOD DR, PO BOX 547	FRANKLIN IN 46131
3M099	PORTLAND SCREW CO	6520 N. BASIN ST	PORTLAND, OR 97217–3920
50394	SPS TECHNOLOGIES INC UNBRAKO DIV	HIGHLAND AVE	JENKINTOWN PA 19046
53387	MINNESOTA MINING MFG CO	PO BOX 2963	AUSTIN TX 78769–2963
61058	MATSUSHITA ELECTRIC CORP OF AMERICA PANASONIC INDUSTRIAL CO DIV	TWO PANASONIC WAY	SECAUCUS NJ 07094
61857	SAN–0 INDUSTRIAL CORP	91–3 COLIN DRIVE	HOLBROOK NY 11741
64537	KDI ELECTRONICS INC SUBSIDIARY OF KDI CORP	31 FARINELLA DR	EAST HANOVER NJ 07936
73743	FISCHER SPECIAL MFG CO	111 INDUSTRIAL RD	COLD SPRING KY 41076–9749
8X345	NORTHWEST SPRING & MFG CO	5858 WILLOW LANE	LAKE OSWEGO OR 97034–5343
80009	TEKTRONIX INC	14150 SW KARL BRAUN DR PO BOX 500	BEAVERTON OR 97077–0001
83486	ELCO INDUSTRIES INC	1101 SAMUELSON RD	ROCKFORD IL 61101
91260	CONNOR SPRING AND MFG CO A SLOSS AND BRITTAN INC CO	1729 JUNCTION AVE	SAN JOSE CA 95112
93907	TEXTRON INC CAMCAR DIV	600 18TH AVE	ROCKFORD IL 61108–5181



Glossary and Index

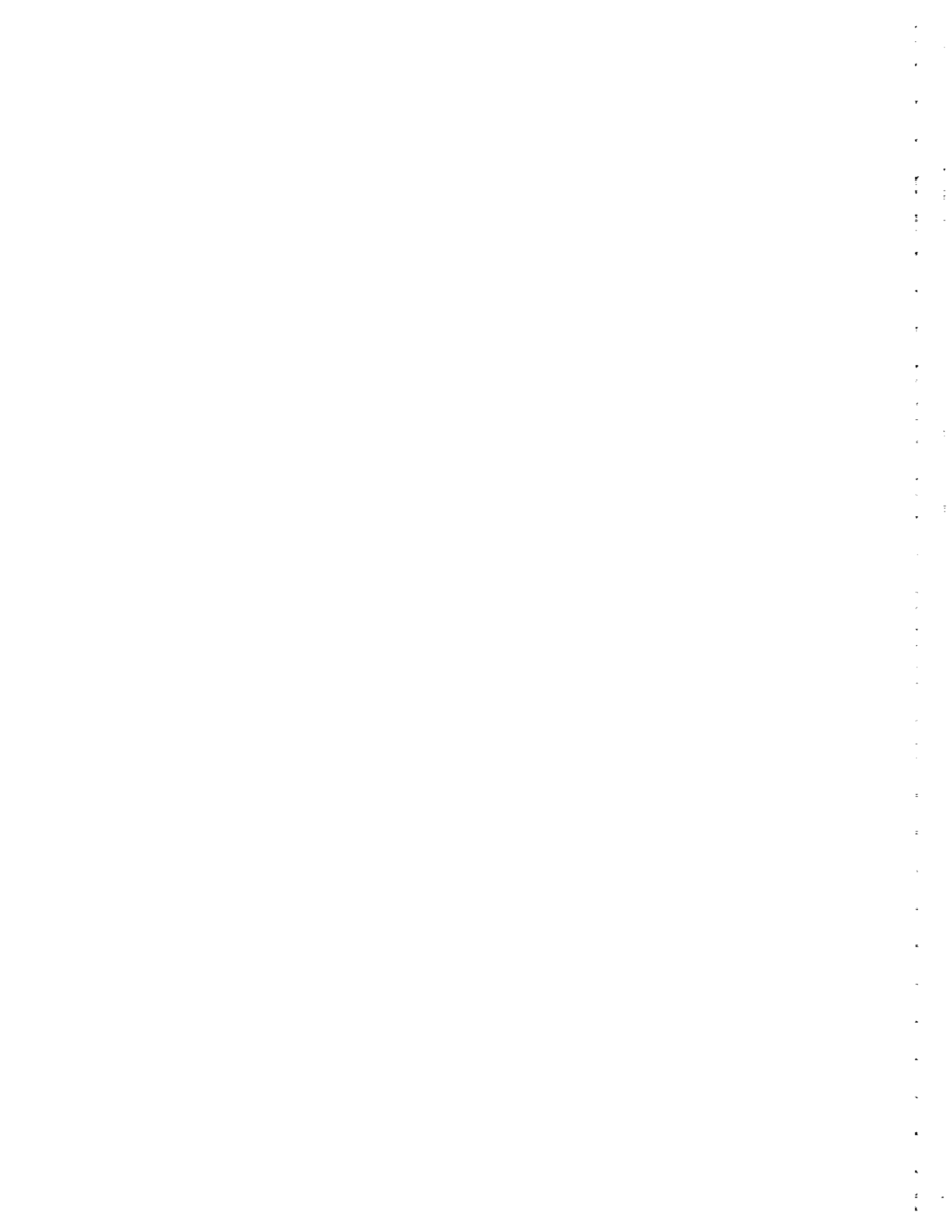

Glossary

amp-second product

The unit of measure defining the maximum amount of pulsed current that can be measured before the probe core becomes saturated. The amp-second rating applies only to measurement values between the maximum continuous and maximum pulse current ratings of the probe. The amp-second rating is equal to the peak current multiplied by the pulse width at the 50% point.

auto-balance

A process that removes unwanted DC offsets from the AM 503B and AM 5030 circuitry to ensure maximum measurement accuracy. This process is performed during the probe degauss routine.

bucking current

Current fed back by the AM 503B and AM 5030 to the current probe during DC and low-frequency AC measurements. Bucking current nulls most of the magnetic field in the probe core, allowing linear DC and AC measurements simultaneously.

conventional current flow

The flow of the positive charge in a conductor. Conventional current flow is from positive to negative. The arrows on current probes point in the direction of conventional current flow. Conventional current flow is in the opposite direction of *electron current flow*.

degauss

A process of eliminating residual magnetism from the probe core by feeding a decaying sine wave into the core. The degaussing process should be performed before clamping the probe around a conductor, whenever the probe becomes saturated by current overloads, or whenever the probe is exposed to a magnetic field. The term is derived from one of the units of magnetic flux density.

electron current flow

The flow of the electrons in a conductor. Electron current flow is from negative to positive. The arrows on current probes point in the opposite direction of electron current flow. Electron current flow is in the opposite direction of *conventional current flow*.

flux

The density of a magnetic field. As the number of flux lines increases, the magnetic field strength increases. Current in the conductor under test generates flux lines in the probe core by inducing a voltage in the core.

Hall device

A thin, rectangular piece of semiconductor material located in the core of the current probe. The Hall device uses the Hall effect for DC and low-frequency AC measurements.

Hall effect

The effect that produces a voltage potential in the Hall device when magnetic lines of force pass through the device. The voltage potential is directly proportional to the magnetic field strength. The voltage polarity is determined by the magnetic field polarity. A bias supply is required to produce the Hall effect. The AM 503B and AM 5030 current probes use the Hall effect for DC and low-frequency AC measurements.

insertion impedance

The equivalent series impedance introduced to a test circuit when the current probe is clamped around a test conductor.

magnetic susceptibility

A figure expressing the amount of current induced into the probe by an external magnetic field of known intensity. The lower the figure is, the less the probe is influenced by external magnetic fields.

saturation

A condition that occurs when the magnetic field strength in the probe core exceeds the maximum level that the core can absorb. When saturation occurs the probe no longer responds linearly to an increase in magnetic field strength, resulting in measurement inaccuracies. A current overload condition will cause core saturation. After saturation occurs, the probe core usually retains residual magnetism which continues to produce inaccuracies until the probe is degaussed. The probe should be degaussed after saturation occurs.

Index

Numbers

20MHz BW LIMIT button, 2-10
20MHz BW LIMIT indicator, 2-10

A

A6302 & A6302XL
adjustments, 6-3
bandwidth check, 5-4
dc accuracy check, 5-8
dc offset adjustment, 6-3
performance verification, 5-3
rise time check, 5-6
A6303, optional gain error adjustment, 6-13
A6303 & A6303XL
adjustments, 6-7
bandwidth check, 5-16
dc accuracy check, 5-20
dc offset adjustment, 6-8
gain adjustment, 6-10
performance verification, 5-15
rise time check, 5-18
transient response adjustment, 6-10
A6304XL
adjustments, 6-15
bandwidth check, 5-30
dc accuracy adjustment, 6-18
dc accuracy check, 5-30
dc offset adjustment, 6-16
performance verification, 5-27
rise time check, 5-28
transient response adjustment, 6-20
AC coupling, 2-4, 2-10, 3-3
adjustments
degauss, 2-3
oscilloscope, 1-7, 7-8
ALLEve? command, 2-21
amp-second product, 3-4, Glossary-1
AMPS Command, 2-21
applications, 3-9
auto-balance, Glossary-1
autobalance function, 2-8

B

bandwidth limits, 2-10, 3-2
battery
low indicator, 3-19

replacement, 7-10
bucking current, 3-6, Glossary-1
BWLIMit Command, 2-22

C

cable
IEEE Std 488.1-1987, 2-13
stacking GPIB, 2-13
changing the operating voltage, 1-4
cleaning, 7-1
commands
ALLEve?, 2-21
AMPS, 2-21
BWLIMit, 2-22
COUpling, 2-22
DCLEVel, 2-23
DEGAuss, 2-23
ERRor?, 2-24
EVEnt?, 2-24
EXit, 2-24
FPLOCK, 2-25
HELp?, 2-25
ID?, 2-26
INIT, 2-26
OVERload?, 2-26
PATH, 2-27
PROBEOPen?, 2-27
PROBETRim, 2-28
PROBETYPe?, 2-29
RQS, 2-29
SERIAL?, 2-30
SET?, 2-30
TEST, 2-31
UNItS?, 2-31
computer, *See* controller, GPIB
connector, IEEE Std 488.1-1987, 2-13
continuity measurements, 3-14
control summary, 2-7
controller, GPIB, 2-13
conventional current, Glossary-1
See also electron current
COUPLING button, 2-10
COUpling Command, 2-22
coupling modes, 3-3
CT-4 high-current adapter, 1-4, 3-7
current limitations
amp-second product, 3-4
maximum continuous, 3-4

- maximum pulsed, 3-4
- current probe calibration, 6-1
- customer support, 1-1

D

- DC coupling, 2-10, 3-3
- DC LEVEL control, 2-4, 2-5, 2-8, 3-3
- DCLEVEL Command, 2-23
- DEGAUSS Command, 2-23
- degauss function, 2-2, 2-8, Glossary-1
- differential current, 3-2
- disassembly
 - front panel, 7-4
 - knobs, 7-4
 - precautions, 7-3
 - release lever, 7-4
 - side covers, 7-4

E

- electron current, Glossary-1
 - See also* conventional current
- error codes, 3-17
 - error 266, 3-19
 - error 357, 3-19
 - I.O., 3-19
- ERRor? Command, 2-24
- EVent? Command, 2-24
- EXit Command, 2-24
- extending the current range of the probes, 3-5

F

- flux, Glossary-1
- FPLOCK Command, 2-25
- frequency derating, 3-4
- front panel controls, 2-7

G

- gain adjustment, *See* trim adjust
- Gauss, Glossary-1
- GPIB
 - Configurations, 2-14
 - Connection rules, 2-14
- GPIB Address, 2-14
- GPIB ADDRESS button, 2-12
- GPIB ADDRESS indicator, 2-12
- GPIB Connector, 2-13
- GPIB Operation, 2-13

- GPIB Parameters, 2-14
- GPIB terminator, 2-12, 2-15

H

- Hall device, Glossary-2
- Hall effect, Glossary-2
- HELp? Command, 2-25

I

- ID? Command, 2-26
- IEEE Std 488.1-1987, 2-13
- increasing bucking current, 3-6
- increasing probe sensitivity, 3-7
- indicator
 - 20MHz BW LIMIT, 2-10
 - GPIB ADDRESS, 2-12
 - OVERLOAD, 2-8
 - PROBE DEGAUSS/AUTOBALANCE, 2-9
 - PROBE OPEN, 2-8
 - REMOTE, 2-12
 - SRQ, 2-12
- inductance measurements, 3-11
- INIT Command, 2-26
- INPUT connector, 2-11
- insertion impedance, Glossary-2

L

- LO error code, 3-19
- locking the probes, 2-1

M

- maintenance, 7-1
- maximum continuous current rating, 3-4
- maximum pulsed current rating, 3-4
- measuring continuity, 3-14
- measuring current
 - AC, 2-4
 - current nulls, 3-2
 - DC, 2-3
 - differential current, 3-2
- measuring inductance, 3-11
- mechanical parts, 8-1

N

- noise, 3-2

null current, 3-2

O

optional accessories, 1-3
output cable, moving, 7-8
OUTPUT connector, 2-11
output, rear interface, 7-8
OVERLOAD indicator, 2-8
OVERload? Command, 2-26

P

PATH Command, 2-27
PROBE DEGAUSS/AUTOBALANCE button, 2-2,
2-8
PROBE DEGAUSS/AUTOBALANCE indicator, 2-9
PROBE OPEN indicator, 2-8
probe trim adjust, 2-10
PROBEOPen? Command, 2-27
probes
bandwidth considerations, 3-2
coupling, 3-3
degaussing (demagnetizing), 2-2, 2-8
description, 1-2
increasing the current limit, 3-5
maintenance, 7-1
maximum current limits, 3-4
operation, 2-1
saturation, 3-4
PROBETrim Command, 2-28
PROBEType? Command, 2-29

R

rear interface output, 7-8
REF coupling, 2-10
release lever, 2-11
REMOTE indicator, 2-12
replaceable mechanical parts, 8-1
RQS Command, 2-29

S

saturation, Glossary-2
SERIAL? Command, 2-30
SET? Command, 2-30
specifications, 4-1
probe serial numbers, 4-1
SRQ indicator, 2-12
susceptibility, Glossary-2

T

termination resistor, 1-7
TEST Command, 2-31
troubleshooting, 3-19

U

UNITs? Command, 2-31

V

voltage selector, 1-4

